

UNIVERSAL SERIES
SHREDDER-FEEDER-EXTRUDER COMBINATION

X:GRAN

- > ONE-STEP technology
- > Process bulky plastic scrap
- > One-button automatic On/Off control
- > DUMP and RUN operation

www.ngr.at

NGR [®]
RECYCLING MACHINES
MEMBER OF NEXT GENERATION GROUP

THE OPERATING PRINCIPLE OF X:GRAN

Plastic waste is processed by a heavy duty shredder operating at low speed for gentle size reduction and minimal loss of material properties. In this process, a hydraulic ram pushes the material to be shredded onto the shredder shaft.

The shredder and extruder drives are controlled separately and automatically, based on load.

After shredding, the ground up material is fed directly into the extruder via the feeder screw. In the extruder, the material is brought to a uniform melt temperature and degassed, if necessary.

All the components are positioned in close proximity to prevent oxidation of the material and to make optimal use of heat from the shredding process.

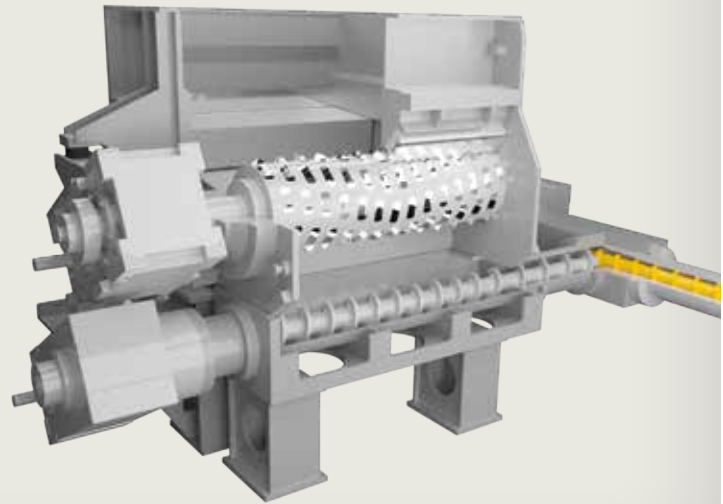

ONE-STEP TECHNOLOGY

In a single process step, the slow-turning shredder blades grind up the plastic waste and the shredded material is then fed continuously to the extruder by the feeder screw.

ONE-BUTTON AUTOMATIC ON/OFF CONTROL

- > Convenient start-up and shut-down
- > Restart after unplanned shutdown in less than two minutes with a full hopper and full extruder
- > The control system provides for smooth start-up of equipment components

PROCESS BULKY PLASTIC SCRAP

Large, thick or bulky waste can be processed without pre-shredding as long as pieces fit into the hopper opening.

DUMP AND RUN OPERATION

- > The material level in the chute is constantly measured and the feed is regulated accordingly
- > Conveyor can be loaded intermittently – the rest is handled by the NGR control unit



HIGH-GRADE RAW MATERIAL

High quality recycled pellets tested to standard EN 15343 et seq.

Very short residence times between shredding and pelletizing

High-performance filtration and degassing of the melt stream

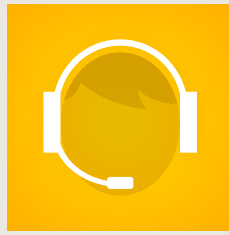

CUSTOMER SERVICE

Test runs with your material at one of our customer care centers

Expert advice in waste management from choosing the right equipment to financing

Commissioning by qualified technicians, rapid on-site service, and internet-based remote maintenance

High availability of spare parts through regional warehouses

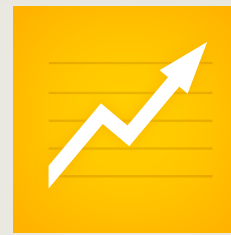

INCREASE PROFITS

Low operating costs with high plastics throughput, minimal power consumption, and easy operation

Space-saving integration in your material logistics chain

Long service life based on solid engineering and high-quality construction

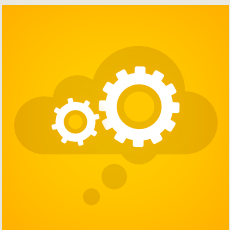

INNOVATIVE TECHNOLOGY

Modular design and platform technology

Customized solutions for your post-industrial or post-consumer plastic waste help you achieve maximum yield

Continual developments in technology keep your waste management solution on the cutting edge

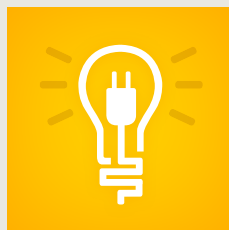

POWER INTELLIGENCE

Power Intelligence is a key concept in the design of high-performance equipment with minimal power and resource requirements

Use of the heat from the shredding process

Closed loop cooling water system

Control unit provides power management

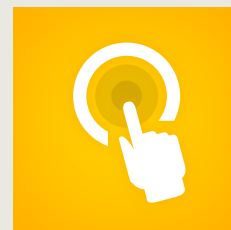

EASY OPERATION

The central operating element controls all equipment functions from feeding to pelletizing, etc.

Easy-to-operate equipment

Simple servicability, allows for fast change of material

The computer-controlled system optimizes the processing steps and stabilizes process parameters

MATERIALS



1. Print-heavy, metal-coated films
2. Ropes, long fibers
3. Compacted EPS blocks
4. Fibers, filaments, tapes
5. Roll scrap without core
6. Textiles, woven fabrics, carpets
7. Start-up lumps
8. Injection molded parts

FEED-IN

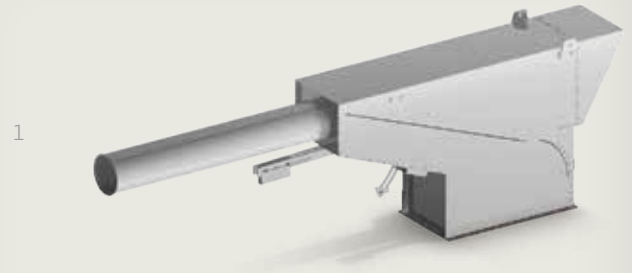

1. AIR SEPARATOR

The air separator is used in the production process to continuously recycle film edge trim. With inline operation, further material handling is unnecessary and the NGR recycling unit is fully automated.

2. ROLL FEEDER

The roll feeder pulls scrap from rolls for processing.

3. CONVEYOR

Conveyor belts are the most universal type of material feed – from start-up lumps to roll scrap without core. The metal detector sounds an alarm to prevent entry from metal debris.



Further materials: PA, PC, PPS, ABS, EVA, biopolymers, blends, etc.



Solid engineering, high-quality materials and precise execution ensure a long service life for equipment.

Maintenance-friendly access to moveable parts allows you to quickly change material, efficiently disassemble and assemble wear and tear parts, and minimizes downtime.

The solidly-constructed, low-speed shredder combined with hydraulic-driven pusher also provides efficient shredding of bulky plastic scrap.

EXTRUDER SCREW

Specially developed for the challenges of recycling, the universal extruder screws provide optimum melt homogeneity and process material efficiently with minimal loss of physical properties.

For special requirements, our expert NGR engineers develop custom-tailored screw geometries.

OPTIONS



CONTROL UNIT

All equipment functions from feeding to pelletizing are controlled automatically from the easy-to-read NGR touchscreen.

Recipes are managed in the operator control unit, which increases traceability, provides ease of use, and ensures equipment parameters are set properly.

1



2



3



1. DOSING

In the area between the feeder screw and the extruder feed-in, additives can be mixed into the material stream on a process-controlled basis.

2. DEGASSING

Depending on the level of contamination and volatile matter in the melt flow, single or double venting is applied. Vacuum-supported venting provides improved degassing for critical applications.

3. MELT FILTER

Double-piston melt filters are factory standard. So screens can be changed at the pistons without interrupting processing. Self-cleaning back flushing melt filters or BRITAS Automatic Band-Melt-Filters with automatic screen changers are recommended for heavily contaminated materials.

PELLETIZATION

1

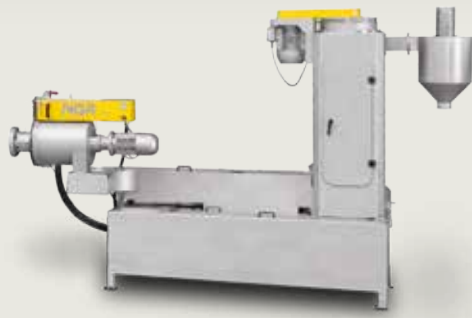

2



1. HOT DIE-FACE PELLETIZER (HD)

HD pelletizing is used for thermoplastics of all types, except for PA 6.6, PET and PBT melts of lower viscosity. Your employees will benefit noticeably from quick and easy configuration of cutter blades, their long periods of use, and the ability to set blade pressure.

3. AUTOMATIC STRAND PELLETIZING (A-SP)

Strand palletizing is used for low-viscosity melts. Uncomplicated operation helps produce uniform and dust-free cylindrical pellets with excellent mixing properties.

PELLETS



In addition to high quality, the uniform pellet size also provides for homogeneous mixture in new material. NGR thus plays an indirect role in ensuring consistent quality in the final product.

X:GRAN

	Ø [mm]	B [mm]	max* [kg/h]	max* [lbs/hr]
X:GRAN 125-140	125	1400	800	1760
X:GRAN 145-140	145	1400	1100	2420
X:GRAN 165-180	165	1800	1400	3080
X:GRAN 185-180	185	1800	1700	3740
X:GRAN 205-180	205	1800	2100	4620
X:GRAN 225-180	225	1800	2600	5730

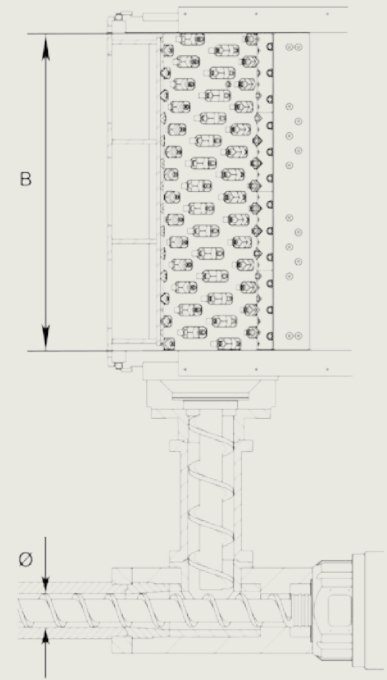

* Output values for LDPE according to NGR company standard, depending on material and quality.

In addition, NGR provides all the equipment for conveying pellets such as blower, pipes, cyclones and much more.

Next Generation Recyclingmaschinen GmbH
HQ, Production & Customer Care Center Europe
 Gewerbepark 22, 4101 Feldkirchen, Austria
 Phone +43 (0) 7233 70 107-0, Fax -2

Taicang Next Generation Recyclingmachines, Co., Ltd.
Sales & Customer Care Center China
 No.6, Wuxi Road, Taicang Economic Development Zone,
 Taicang, Jiangsu 215400, China
 Phone +86 (0) 512 536 52-100, Fax -332

Next Generation Recycling Machines, Inc.
Sales & Customer Care Center America
 3000 Center Place, Suite 100, Norcross, GA 30093, USA
 Phone +1-678-720-9861, Fax -9863
 Toll Free (USA only) +1-877-640-2828

info@ngr.at, www.ngr.at