

# HYDRAULIC BOX DUMPER

*Lift and Dump*

*Smart Solutions To Keep You Moving!*

Ensign is an industry leader in controlled dumping technology.

From standard products to automated systems, our full line of dumpers are designed to move your materials from bulk containers to your processing systems efficiently and effectively.

Constructed from mild or stainless steel, our equipment is offered in several sizes, capacities and options to meet the spectrum of process requirements.

Ensign dumpers are built with pride using only high quality components and designed for years of trouble-free operation. If you should ever need it, superior customer service is immediately available from the Ensign Service Team. Most parts are in stock and available to ship same day.

**Key features:**

- Heavy duty steel and stainless steel construction
- Ground entry loading
- 2500lbs lift capacity
- IPTCI replaceable 2" pivot bearings
- Allen Bradley, Eaton and Hoffman electrical components
- Dual hydraulic tilt cylinders, 2" bore, 1.5" rod
- Bronze pivot cylinder bushings
- 3" cylinder and heavy duty dual chain lift system
- Heavy duty roller bearing and I-beam lift track system
- Remote hydraulic power pack
- Industry leading two year warranty on all parts and workmanship

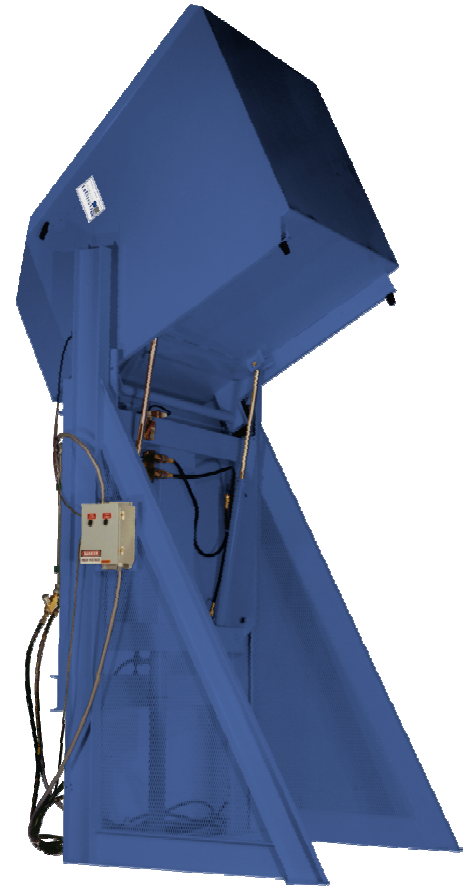

*See back page for additional options and specifications.*

# Hydraulic Box Dumper - Lift and Dump

## Standard Features:

- Ground entry loading
- 135 degree bucket rotation
- Dual hydraulic tilt cylinders, 2" bore, 1.5" rod
- Dual acting hydraulics
- Hydraulic velocity fuse for added safety
- Remote hydraulic power pack
- NEMA 12 control panel w/ momentary up / down push buttons
- Up cycle complete limit switch
- Roller type pivot bearings for high cycle operations
- Adjustable retaining bar 32" - 48"
- Ensign Blue Epoxy

## Optional Features:

- Auto / manual tilt controls & automation
- Side load / dump available
- Custom bucket widths, sizes & capacities
- Work platforms
- Faster cycle times
- Floor grates
- Auto seal lids
- Safety cages
- Dust hoods and special discharge gates
- Stainless steel bucket, chutes and liners
- UHMW protective liners
- Custom Paints and Coatings

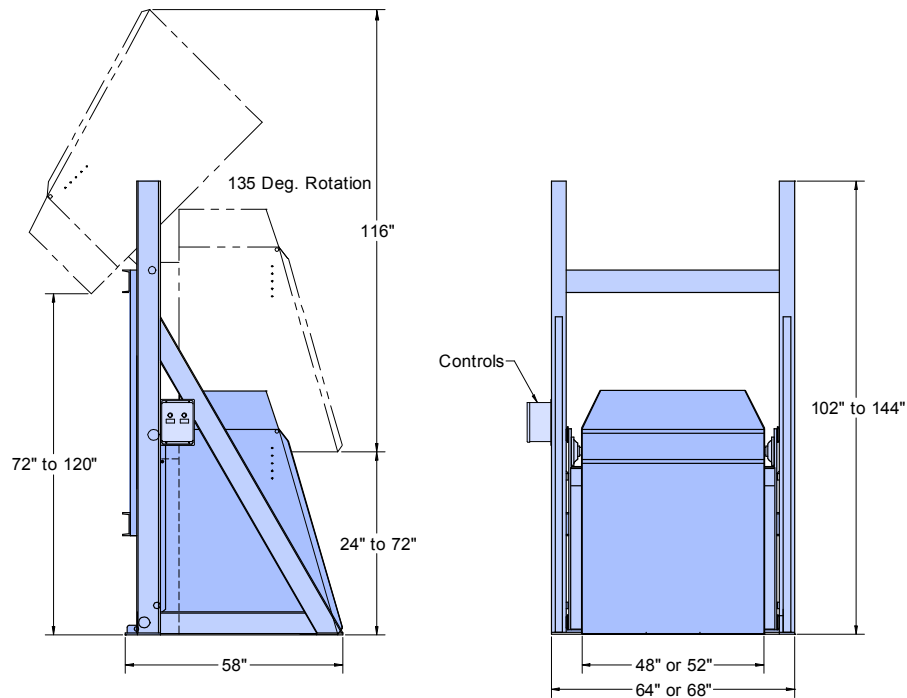

Model No.	Description	Dump Height	Bucket Width	Lift / lbs
39-2000	Lift and Dump	66" - 90"	48"	2500
39-2500	Lift and Dump	91" - 114"	48"	2500
39-3000	Lift and Dump	115" - 138"	48"	2500
39-3500	Lift and Dump	139" - 162"	48"	2500
39-4000	Lift and Dump	163" - 186"	48"	2500

Standard models listed above. Other sizes, widths and capacities available.

**ENSIGN EQUIPMENT INC.**  
12523 Superior Court  
Holland, MI 49424

ph: 616.738.9000 (or) 800.753.8947  
fax: 616.738.9001

www.ensigneq.com  
sales@ensigneq.com

