

*Smart Solutions To Keep You Moving!*

Ensign's material storage bins, also known as surge bins or day bins, are an economical in-plant storage solution for almost any material handling system.

Ranging in sizes from 25 cubic feet capacity to 600 cubic feet capacity, Ensign can provide in-plant storage bins to receive material from silos, rail unloading systems or gravity fill methods such as screw conveyors or dumpers.

When you're ready to move material to the point-of-use, you can use our industry standard vacuum components or gravity discharge into Gaylords or Porta-Stors.

What ever your process requirements, we look forward to providing a smart solution for you!

**Key features:**

- Fill using hydraulic box dumpers, screw conveyor or vacuum systems
- Industry standard or custom discharge flanges
- Adaptable to almost any vacuum or gravity discharge process
- Weigh systems (available)
- Level control (available)
- Custom platforms, ladders & hand rails (available)
- Many more features and options available
- Industry leading two year warranty on all parts and workmanship



*See back page for additional options and specifications.*

# Material Storage Bins

## Standard Features:

- Heavy duty steel construction
- Loader mounting pattern
- 1/3 hinged cover
- Industry standard discharge flange
- Bolt down foot pads
- Ensign Blue Epoxy

## Optional Features:

- Stainless steel construction
- Weigh systems
- Level control
- Vacuum take-away boxes (VTA's)
- Screw conveyor take-away
- Vent filter
- Work platforms & ladders
- Slide gates
- Special discharge flanges
- View window

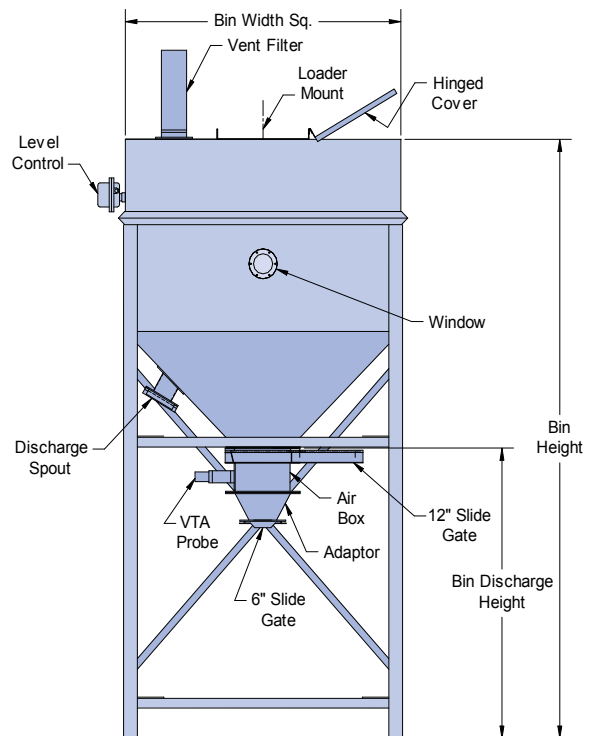

Capacity (level full)	Weight (Lbs—Max)	L x W	Slope	Model	Discharge Height	Overall Height	Model	Discharge Height	Overall Height
38 cu ft	1900	48"x48"	45 deg	44-4500	18"	4'9"	44-8500 *	60"	8'3"
54 cu ft	2700	48"x48"	45 deg	44-4600	18"	5'9"	44-8600 *	60"	9'3"
70 cu ft	3500	48"x48"	45 deg	44-4800	18"	6'9"	44-8800 *	60"	10'3"
70 cu ft	3500	60"x60"	45 deg	45-4500	18"	5'6"	45-5500	60"	9'0"
95 cu ft	4750	60"x60"	45 deg	45-4600	18"	6'6"	45-5600	60"	10'0"
145 cu ft	7250	60"x60"	45 deg	45-4800	18"	8'6"	45-5800	60"	12'0"
195 cu ft	9750	60"x60"	45 deg	45-4900	18"	10'6"	45-5900	60"	14'0"
192 cu ft	9600	72"x72"	45 deg	46-4800	18"	8'4"	46-5800	60"	11'10"
264 cu ft	13,200	72"x72"	45 deg	46-4900	18"	10'4"	46-5900	60"	13'10"
47 cu ft	2350	48"x48"	60 deg	44-6500	18"	5'11"	44-9500 *	60"	9'5"
63 cu ft	3150	48"x48"	60 deg	44-6600	18"	6'11"	44-9600 *	60"	10'5"
75 cu ft	3750	60"x60"	60 deg	45-6600	18"	6'10"	45-7600	60"	10'4"
125 cu ft	6250	60"x60"	60 deg	45-6800	18"	8'10"	45-7800	60"	12'4"
175 cu ft	8750	60"x60"	60 deg	45-6900	18"	10'10"	45-7900	60"	14'4"
162 cu ft	8100	72"x72"	60 deg	46-6800	18"	8'9"	46-7800	60"	12'3"
234 cu ft	11,700	72"x72"	60 deg	46-6900	18"	10'9"	46-7900	60"	14'3"

\* Front legs spread to 48" wide for Gaylord clearance

**ENSIGN EQUIPMENT INC.**  
12523 Superior Court  
Holland, MI 49424

ph: 616.738.9000 (or) 800.753.8947  
fax: 616.738.9001

www.ensigneq.com  
sales@ensigneq.com

