

CATALOG
C24

EMI[®]

CONVEYORS &
AUTOMATION SYSTEMS



Signature Line RM Steel Frame | Flat Belt

Standard belt widths: 6"–96" at 6" increments

Standard lengths: 3–50' at 1' increments

*Consult your EMI representative for other widths and lengths

These strong conveyors have a multitude of uses: under press, along side the press, trunk line systems, overhead and assembly station conveyors, etc. Standard units are rated for a 150 lb. maximum load capacity, but higher capacities are available when needed. Selection of belt speeds are available. Drive horsepower will depend on selected speed and conveyor length, see page 170. Modular construction allows field changes of lengths.



Click for 360° View!

Features

- Direct Drive configuration with 1/3 hp AC motor.
- 4–40 FPM variable speed drive.
- 150 lb maximum load.
- No roller chain or sprockets.
- Sealed gear reducer.
- 12-gauge steel construction.
- Double V-guided, 3'–30' lengths, FDA approved, white PVC belt.
- Leg sets and swivel castors included.
- 4" tall side rails, lapped over conveyor belt.
- 15' power cord included. Pre-wired ready to run (except polyphase systems which require some customer wiring).
- Control wiring contained in liquid-tight conduit and connectors.
- Units up to 10' length ship fully assembled.
- 3-Year Limited Warranty, see page 3.



Shown with optional CLR leg set.

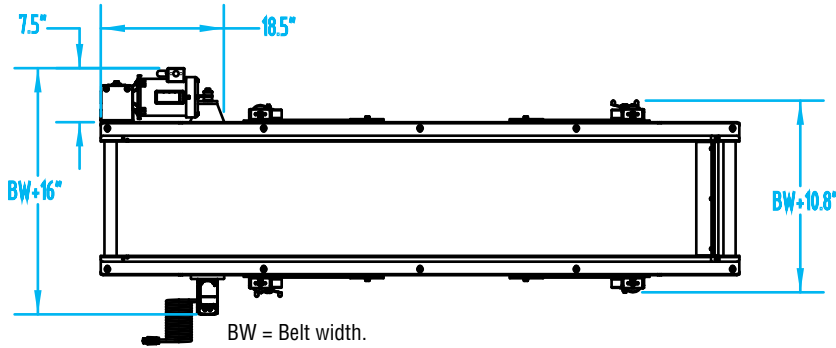

Click for 360° View!

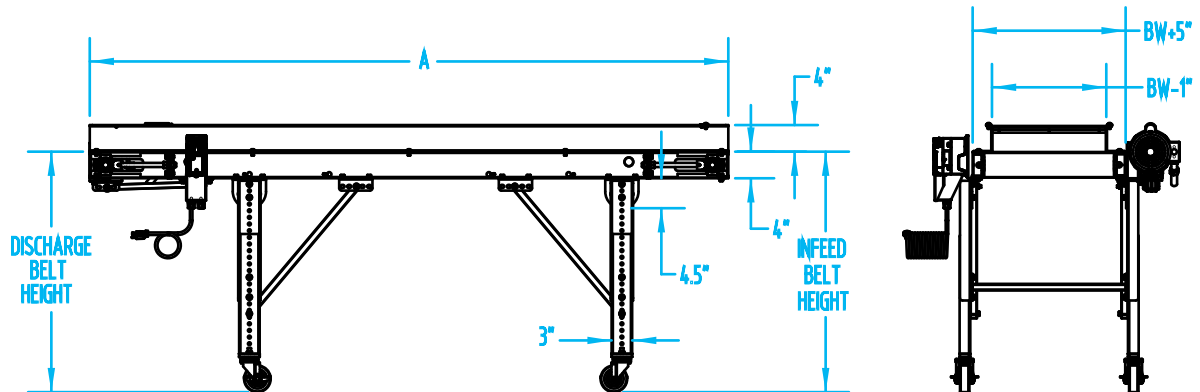

How to Order:

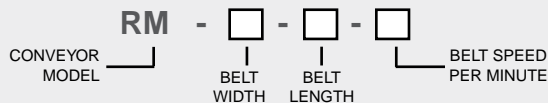

Specify the conveyor Infeed and Discharge Belt Height.
 For more lengths, see RMTL on page 74.
 Download Conveyor Specifications Form [here](#).

Common Options

- Alternate fixed and variable belt speeds available.
- Alternate voltage electrics.
- Side rail extensions.
- Reversing, for process control.
- Soft drop zone, to cushion part drop.
- Side belt guards for part containment.
- Alternate motor locations, see page 177.
- Numerous belt options, see page 106.
- Robotic and box-fill controls.