

CATALOG
C24

EMI[®]

CONVEYORS &
AUTOMATION SYSTEMS



Signature Line RMTL | Flat Belt Trunkline

Standard belt widths: 12"–96" at 6" increments

Standard lengths: 51–250' at 1' increments

*Consult your EMI representative for other widths and lengths

EMI Trunkline Conveyors incorporate rugged cross-bracing and sturdy construction for long distance runs. The end-mounted drives assure reliable belt tracking. Conveyors 51' through 180' long incorporate a 6" diameter drive pulley mounted in a 7" thick frame section and can carry up to 250 lbs. Conveyors 181' through 250' long have an 8" diameter drive pulley mounted in a 9" thick frame section and can carry up to 300 lbs. These heavier drive sections allow the rest of the conveyor frame to be only 4" thick. Higher load capacity drives are available.

Features

- Direct Drive configuration with 1/2 hp AC motor.
- 4–40 FPM variable speed drive.
- No roller chain or sprockets.
- Sealed gear reducer.
- 12-gauge steel construction.
- FDA approved, white PVC belt.
- End-mounted drive ensures reliable belt tracking.
- 4" tall side rails, lapped over conveyor belt.
- 15' power cord included. Pre-wired, ready to run (except polyphase systems which require some customer wiring).
- Control wiring in liquid-tight conduit and connectors.
- 3-Year Limited Warranty, see page 3.

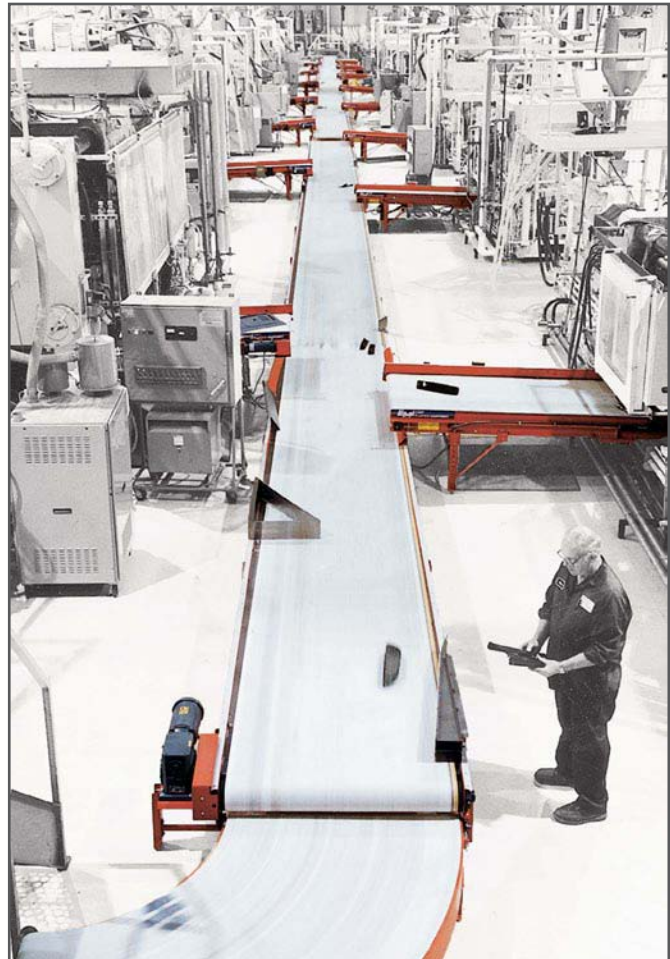

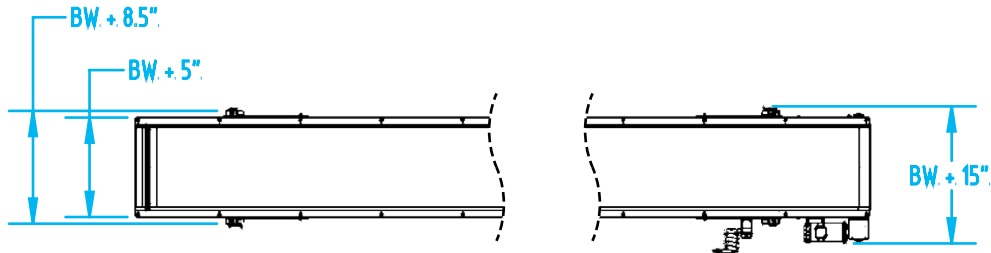

BW = Belt width.

NOTE: The thickness of frame section is 7" for 51' through 180' long conveyors, 9" for 181' through 250' long conveyors.

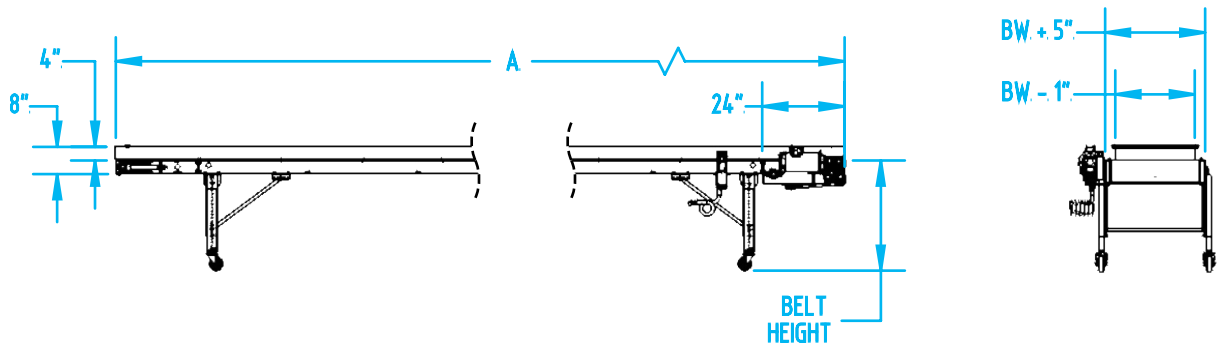

How to Order:

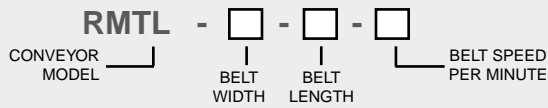

Specify the conveyor Infeed Belt Height and Motor Starter Location. Standard Belt Speeds are 40 FPM & 80 FPM. Horsepower charts are on page 170. Download Conveyor Specifications Form here.

Common Options

- Alternate fixed and variable belt speeds available
- Alternate voltage electrics
- Many more available

