

CATALOG
C24

EMI[®]

CONVEYORS &
AUTOMATION SYSTEMS



Trim Line

ATLK Aluminum Frame | Adjustable Angle

Standard belt widths: 6", 9", 12", 18", 24"

Standard lengths: up to 15' at 1' increments

An adjustable angle of 20°–45°, makes the Trim Line Adjustable Angle conveyor perfect for under or along side the press or for moving parts to a trunkline, work station, or automatic box filling system. Horizontal to inclined transition rollers eliminate pinch points and assure smooth part transfer. Angles and leg sets are adjustable. A range of options allow Trim Line Conveyors to be customized to suit many applications.



Click for 360° View!

Features

- Direct Drive ¼ hp 110V input AC variable-speed drive package.
- No roller chain or sprockets.
- Sealed gear reducer.
- 50 lb. maximum load.
- ⅛" anodized aluminum construction.
- Adjustable angle incline 20°–45°.
- Double V-guided, FDA approved, white PVC belt with 1½" tall cleats on 18" centers.
- 4" tall side rails, lapped over conveyor belt.
- Leg sets and swivel castors included.
- 15' power cord included. Pre-wired ready to run (except polyphase systems which require some customer wiring).
- Control wiring contained in liquid-tight conduit and connectors.
- Units up to 10' overall length ship fully assembled.
- 3-Year Limited Warranty, see page 3.

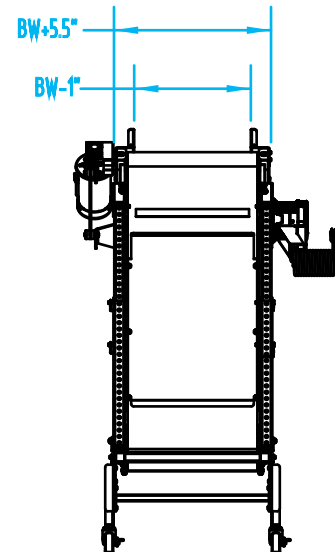
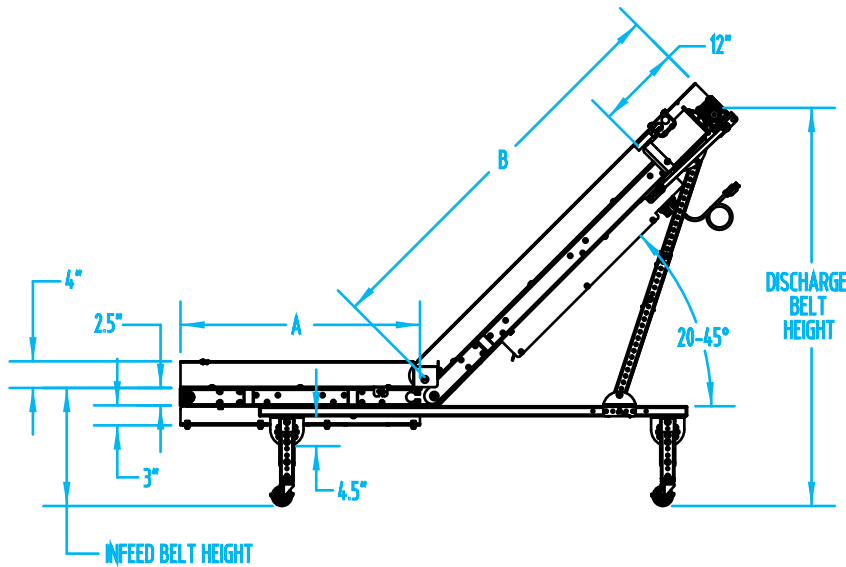
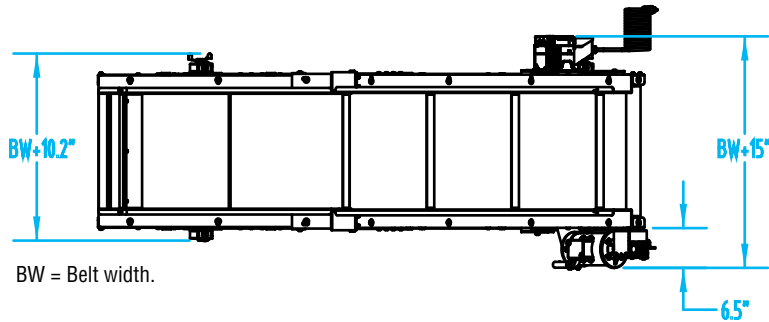

How to Order:

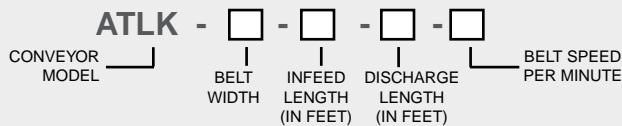

Specify the conveyor Infeed and Discharge Belt Height. Download Conveyor Specifications Form [here](#).

For 6", 9", 12", and 18" belt width models, the motor is located at the discharge. For 24" wide models, the motor is located at the infeed. The "A" dimension infeed length minimum is 2'. The "B" dimension incline length minimum is 2'. Contact EMI if A + B exceeds 15'.

Common Options

- Discharge chute.
- Alternate conveyor speeds.
- Side rail extensions for part containment.
- Soft drop zone.
- Alternate motor locations, see page 177.
- Numerous belt options, see page 106.