

# Accuchiller NQ Series

## Portable & Packaged Industrial Chillers

### Benefits:

- **Low GWP R-454B Refrigerant: NEW!**  
EPA approved refrigerant provides a Global Warming Potential rating below 700 to combat climate change issues.
- **Direct Drive Scroll Compressors:**  
Hermetically sealed scroll compressors with proven performance in industrial cooling for reliable, low maintenance, and efficient operation.
- **Stainless Steel Evaporators:** High efficiency stainless steel plates with copper brazing provide maximum performance, long life, and an enhanced level of protection from harsh process conditions.
- **Stainless Steel Pumps:** Selected for peak performance with the utmost in corrosion protection to ensure a long useful life under severe industrial conditions.
- **Nonferrous Reservoir and Water Lines:** Insulated reservoir, fluid lines, pumps, and other components in the process fluid circuit will remain free of rust for maximum corrosion protection.
- **Evaporator Inlet Strainer:** Removes any debris present in the process fluid to prevent costly downtime and repair due to a clogged chiller evaporator.
- **Wide Ambient Range:** Indoor duty air cooled, water cooled, or remote air cooled condensers as well as outdoor air cooled chillers fit a variety of applications.
- **Warranty:** 18 months parts on entire unit; 12 months labor.



The Accuchiller NQ Series offers a versatile line of portable and packaged chillers designed for efficient and reliable temperature control. These durable units feature a compact footprint with an easily accessible interior, making them ideal for diverse applications.

NQ Series chillers are available with air cooled, water cooled, or remote condenser options. Each model is packed with innovative features that optimize performance and reliability. Scroll compressors, microchannel condensers, stainless steel brazed plate evaporators, and low-noise

fans ensure smooth operation and energy savings. The user-friendly PLC control system with a large color touchscreen provides intuitive operation, advanced diagnostics, and precise temperature control. With its compact footprint, user-friendly controls, and innovative features, the Accuchiller NQ Series delivers the ultimate in chiller performance and reliability.

For even great efficiency, consider the Accuchiller NQV Series chillers with variable speed scroll compressor available from 5 to 30 tons (18 to 106 kW).

## Benefits of the NQ Series Industrial Chiller Features:

### HIGH EFFICIENCY FANS

Air-cooled units with integral condensers feature totally enclosed air over (TEAO) motors for long life and reliability.

### REMOVABLE AND CLEANABLE FILTERS

Protects the internal components of the chiller.



### 7-INCH COLOR TOUCH SCREEN

Allows monitoring of chiller operation and easy set point control.

### STAINLESS STEEL PROCESS PUMP

Use of premium components provide protection against rust and corrosion for reliability and long life.

### NEW! ELECTRONIC EXPANSION VALVE

Provides precise refrigerant flow control for optimal system efficiency and improved temperature stability.

## Additional Benefits:

- **Easy Access Cabinet:** Heavy-gauge machine access doors with industrial grade tools-free latches provide quick access to all components for easy operation and maintenance.
- **Compressor Protection Technology:** Uses start-to-start anti-recycle control logic to limit cycling under low-load operating conditions to extend compressor life.
- **Compressor and Pump Run Hour Displays:** Monitor compressor and pump running hours to assist with scheduling maintenance.
- **Power Monitor:** Protects the chiller from extensive damage to the compressor and pump due to loss of phase or phase reversal in the main supply.
- **Reservoir Low Level Alarm:** Indicates a low process fluid condition and protects the process pump and chiller from damage caused by a critically low operating level in the reservoir.
- **Temperature Deviation Warnings and Alarms:** Alerts the operator of a potential problem before a fault occurs and if the condition gets worse, an alarm stops the chiller to prevent damage.
- **Adjustable Deviation Alarm Time Delays:** Allows for programming a start-up alarm time delay to deactivate the alarms long enough for the process loop to stabilize before activating the alarms.
- **High-Quality 24 VDC Power Supply:** Ensures dependable control circuit power and isolates the control circuit from static interference for stable and precise operation.
- **Modbus RTU:** Communications protocol.

## Available Options:

- High flow/high pressure pumps
- High flow unit design
- Alarm horn
- Alarm relay
- Rotary non-fused or fused disconnect switch
- C-UL508A industrial control panel construction
- Outdoor-duty construction
- Indoor duty low temperature (0°F to 120°F; -18°C to 49°C)
- Outdoor duty temperature (-20°F to 120°F; -29°C to 49°C)
- Air-cooled condenser coating for coastal regions
- Pump and tank deduct
- Oversized reservoirs
- Water circuit for use with de-ionized water
- Stainless steel cabinetry
- Automatic electric water make-up valve
- High pressure fans for ducting of discharge air
- Emergency stop button
- Remote HMI with 50 foot wire
- Special color paint
- 5 year compressor parts warranty

## 7-Inch Color Touch Screen

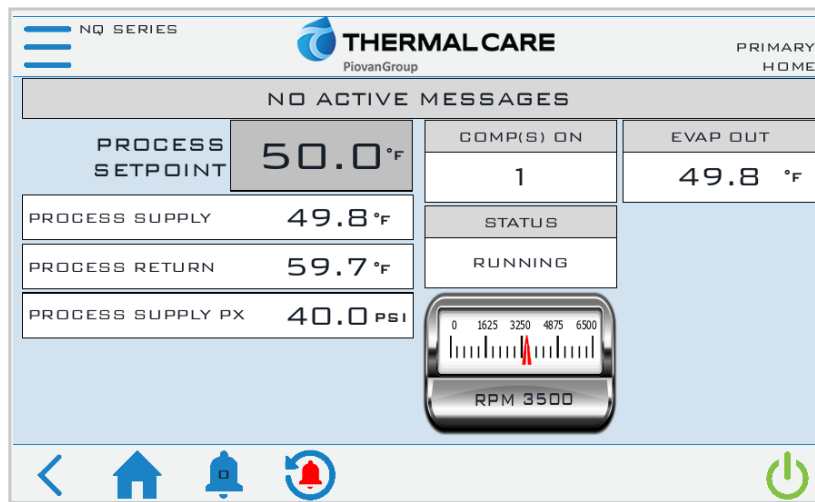

Home Screen

## Control Features

Description of Functions	Standard Controls	Premium Controls
<b>Display Parameters</b>		
Process Fluid Supply and Return Temperatures	●	●
Evaporator Fluid Leaving Temperature	●	●
Process Fluid Supply Pressure	●	●
Compressor Running Hours	●	●
Pump Running Hours	●	●
Condenser Fan Running Hours	●	●
Refrigerant Suction Pressure	●	●
Refrigerant Suction Temperature and Superheat	●	●
Refrigerant Liquid Temperature and Subcooling	●	●
Refrigeration Discharge Pressure	●	●
Refrigerant Discharge Temperature	●	●
<b>Alarms and Warnings</b>		
A2L Refrigeration	○	○
High Process Fluid Temperature	●	●
Low Process Fluid Temperature	●	●
Evaporator Fluid Freeze	●	●
Evaporator Fluid Low Flow	●	●
Refrigerant High Pressure	●	●
Refrigerant Low Pressure	●	●
Compressor Overload	●	●
Pump Overload	●	●
Condenser Fan Overload	●	●
Reservoir Low Level	●	●
<b>Communications and Remote Interfaces</b>		
Process Fluid Supply Temperature (0-10 VDC)	●	●
Remote Start / Stop	●	●
Alarm Contact	●	●
CONNEX4.0 Ready	●	●
Modbus RTU	●	●
Modbus TCP / IP	—	●
BACnet MS / TP	—	○
BACnet / IP	—	○
Primary / Secondary Chiller Control	—	○

**Legend:**      Standard = ●      Optional = ○      Not Available = —

## Technical Data

Air Cooled Condenser Chillers	NQA04	NQA05	NQA08	NQA10	NQA13
<b>Cooling Capacity<sup>1</sup></b>	4 tons 14 kW	5 tons 18 kW	8 tons 28 kW	11 tons 39 kW	13 tons 46 kW
<b>Set Point Range</b>	20 to 80°F -7 to 27°C	20 to 80°F -7 to 27°C	20 to 80°F -7 to 27°C	20 to 80°F -7 to 27°C	20 to 80°F -7 to 27°C
<b>Compressor (qty)</b>	1	1	1	1	1
<b>Sound Pressure @ 1 meter (dBA)</b>	74	74	76	76	76
<b>Pump Motor Size</b>	2 hp 1.5 kW	2 hp 1.5 kW	2 hp 1.5 kW	3 hp 2.2 kW	3 hp 2.2 kW
<b>Pump Flow</b>	10 gpm 38 lpm	12 gpm 45 lpm	19 gpm 72 lpm	27 gpm 102 lpm	30 gpm 114 lpm
<b>Net Available Pump Pressure<sup>2</sup></b>	43 psi 3.0 bar	41 psi 2.8 bar	41 psi 2.8 bar	48 psi 3.3 bar	46 psi 3.2 bar
<b>Reservoir Holding Capacity</b>	11 gal 42 L	11 gal 42 L	30 gal 114 L	30 gal 114 L	30 gal 114 L
<b>Dimensions L x W x H inch (mm)</b>	48 x 34 x 64 (1,219 x 864 x 1,626)	48 x 34 x 64 (1,219 x 864 x 1,626)	75 x 34 x 64 (1,905 x 864 x 1,626)	75 x 34 x 64 (1,905 x 864 x 1,626)	75 x 34 x 64 (1,905 x 864 x 1,626)
<b>Shipping Weight</b>	720 lbs 327 kg	720 lbs 327 kg	1,195 lbs 542 kg	1,195 lbs 542 kg	1,215 lbs 551 kg
<b>Operating Weight</b>	810 lbs 367 kg	810 lbs 367 kg	1,380 lbs 626 kg	1,380 lbs 626 kg	1,400 lbs 635 kg

Air Cooled Condenser Chillers (additional models)	NQA15	NQA20	NQA25	NQA30
<b>Cooling Capacity<sup>1</sup></b>	15 tons 53 kW	21 tons 74 kW	26 tons 91 kW	31 tons 109 kW
<b>Set Point Range</b>	20 to 80°F -7 to 27°C	20 to 80°F -7 to 27°C	20 to 80°F -7 to 27°C	20 to 80°F -7 to 27°C
<b>Compressor (qty)</b>	1	2	2	2
<b>Sound Pressure @ 1 meter (dBA)</b>	82	84	84	86
<b>Pump Motor Size</b>	3 hp 2.2 kW	3 hp 2.2 kW	3 hp 2.2 kW	5 hp 3.7 kW
<b>Pump Flow</b>	36 gpm 136 lpm	48 gpm 182 lpm	60 gpm 227 lpm	72 gpm 273 lpm
<b>Net Available Pump Pressure<sup>2</sup></b>	40 psi 2.8 bar	45 psi 3.1 bar	48 psi 3.3 bar	43 psi 3.0 bar
<b>Reservoir Holding Capacity</b>	60 gal 227 L	60 gal 227 L	67 gal 254 L	67 gal 254 L
<b>Dimensions L x W x H inch (mm)</b>	87 x 41 x 95 (2,210 x 1,041 x 2,413)	87 x 41 x 95 (2,210 x 1,041 x 2,413)	105 x 41 x 95 (2,667 x 1,041 x 2,413)	105 x 41 x 95 (2,667 x 1,041 x 2,413)
<b>Shipping Weight</b>	3,200 lbs 1,452 kg	3,300 lbs 1,497 kg	3,800 lbs 1,724 kg	4,150 lbs 1,882 kg
<b>Operating Weight</b>	3,535 lbs 1,603 kg	3,715 lbs 1,685 kg	4,360 lbs 1,978 kg	4,710 lbs 2,136 kg

<sup>1</sup>Cooling tons based on 12,000 BTU/Hr/ton with 50°F (10°C) leaving coolant and 95°F (35°C) ambient air, R410A or R454B refrigerant.

<sup>2</sup>Net available pressure at outlet of chiller is pump discharge pressure less the internal pressure loss through the fluid circuit.

<sup>3</sup>Units with variable speed fans are 2 in (51 mm) taller.

## NQA04 - NQA13

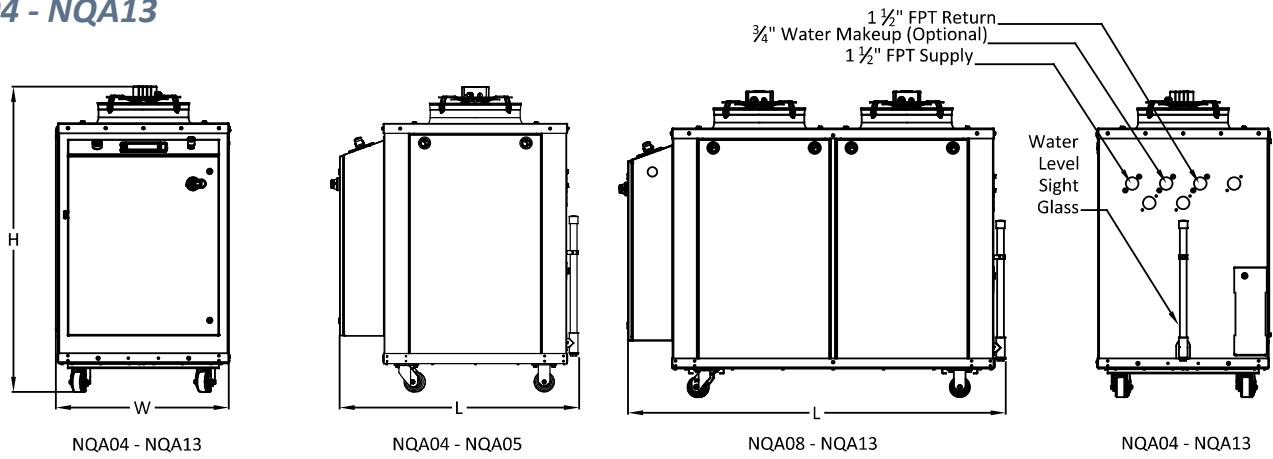

## NQA15 - NQA30

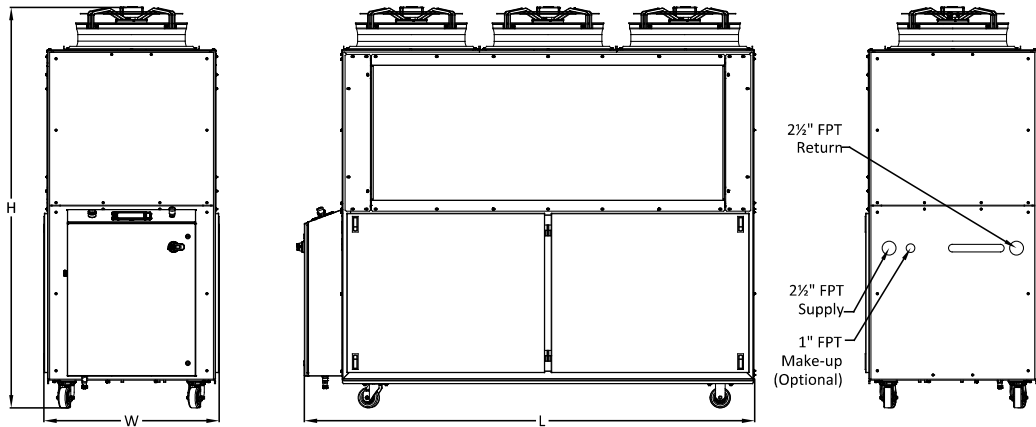

Water Cooled Condenser Chillers	NQW05	NQW08	NQW10	NQW15	NQW20
<b>Cooling Capacity<sup>1</sup></b>	6 tons 21 kW	8 tons 28 kW	12 tons 42 kW	17 tons 60 kW	23 tons 81 kW
<b>Set Point Range</b>	20 to 80°F -7 to 27°C	20 to 80°F -7 to 27°C	20 to 80°F -7 to 27°C	20 to 80°F -7 to 27°C	20 to 80°F -7 to 27°C
<b>Compressor (qty)</b>	1	1	1	1	2
<b>Sound Pressure @ 1 meter (dBA)</b>	70	70	71	73	74
<b>Pump Motor Size</b>	2 hp 1.5 kW	2 hp 1.5 kW	3 hp 2.2 kW	3 hp 2.2 kW	5 hp 3.7 kW
<b>Pump Flow</b>	13 gpm 49 lpm	20 gpm 76 lpm	29 gpm 110 lpm	39 gpm 148 lpm	54 gpm 204 lpm
<b>Net Available Pump Pressure<sup>2</sup></b>	40 psi 2.8 bar	40 psi 2.8 bar	46 psi 3.2 bar	35 psi 2.4 bar	41 psi 2.8 bar
<b>Reservoir Holding Capacity</b>	11 gal 42 L	30 gal 114 L	30 gal 114 L	30 gal 114 L	60 gal 227 L
<b>Dimensions L x W x H inch (mm)</b>	48 x 34 x 53 (1,219 x 864 x 1,346)	75 x 34 x 53 (1,905 x 864 x 1,346)	75 x 34 x 53 (1,905 x 864 x 1,346)	75 x 34 x 53 (1,905 x 864 x 1,346)	87 x 41 x 47 (2,210 x 1,041 x 1,194)
<b>Shipping Weight</b>	720 lbs 327 kg	1,195 lbs 542 kg	1,195 lbs 542 kg	1,315 lbs 597 kg	1,900 lbs 862 kg
<b>Operating Weight</b>	810 lbs 367 kg	1,380 lbs 626 kg	1,380 lbs 626 kg	1,500 lbs 680 kg	2,315 lbs 1,050 kg

Water Cooled Condenser Chillers (additional models)	NQW25	NQW30	NQW35	NQW40
Cooling Capacity <sup>1</sup>	28 tons 98 kW	33 tons 116 kW	38 tons 134 kW	43 tons 151 kW
Set Point Range	20 to 80°F -7 to 27°C	20 to 80°F -7 to 27°C	20 to 80°F -7 to 27°C	20 to 80°F -7 to 27°C
Compressor (qty)	2	2	2	2
Sound Pressure @ 1 meter (dBA)	74	75	77	78
Pump Motor Size	5 hp 3.7 kW	5 hp 3.7 kW	5 hp 3.7 kW	5 hp 3.7 kW
Pump Flow	67 gpm 254 lpm	79 gpm 299 lpm	92 gpm 348 lpm	102 gpm 386 lpm
Net Available Pump Pressure <sup>2</sup>	44 psi 3.0 bar	39 psi 2.7 bar	38 psi 2.6 bar	34 psi 2.3 bar
Reservoir Holding Capacity	60 gal 227 L	67 gal 254 L	67 gal 254 L	67 gal 254 L
Dimensions L x W x H inch (mm)	87 x 41 x 47 (2,210 x 1,041 x 1,194)	105 x 41 x 47 (2,667 x 1,041 x 1,194)	105 x 41 x 47 (2,667 x 1,041 x 1,194)	105 x 41 x 47 (2,667 x 1,041 x 1,194)
Shipping Weight	2,100 lbs 953 kg	2,250 lbs 1,021 kg	3,400 lbs 1,542 kg	3,900 lbs 1,769 kg
Operating Weight	2,515 lbs 1,141 kg	2,810 lbs 1,275 kg	3,960 lbs 1,796 kg	4,460 lbs 2,023 kg

<sup>1</sup>Cooling tons based on 12,000 BTU/Hr/ton with 50°F (10°C) leaving coolant and 85°F (29°C) condenser water, R410A or R454B refrigerant.

<sup>2</sup>Net available pressure at outlet of chiller is pump discharge pressure less the internal pressure loss through the fluid circuit.

### NQW05 - NQW15

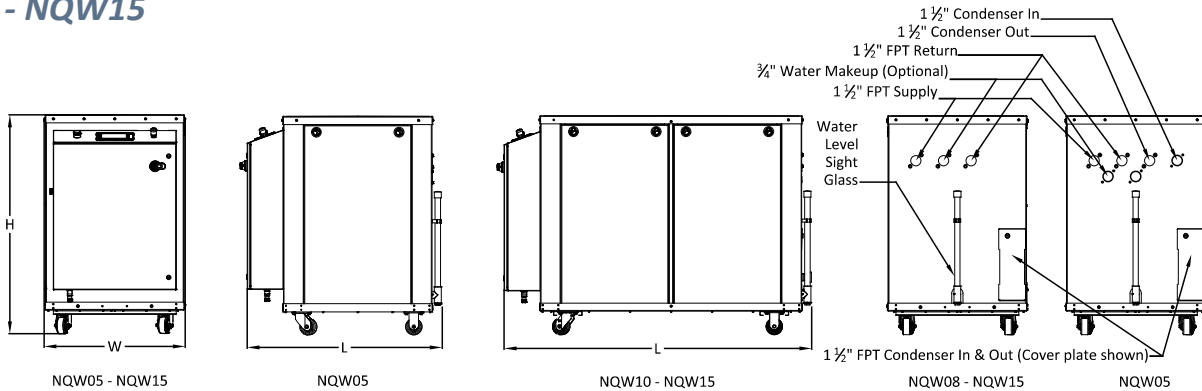

### NQW20 - NQW40

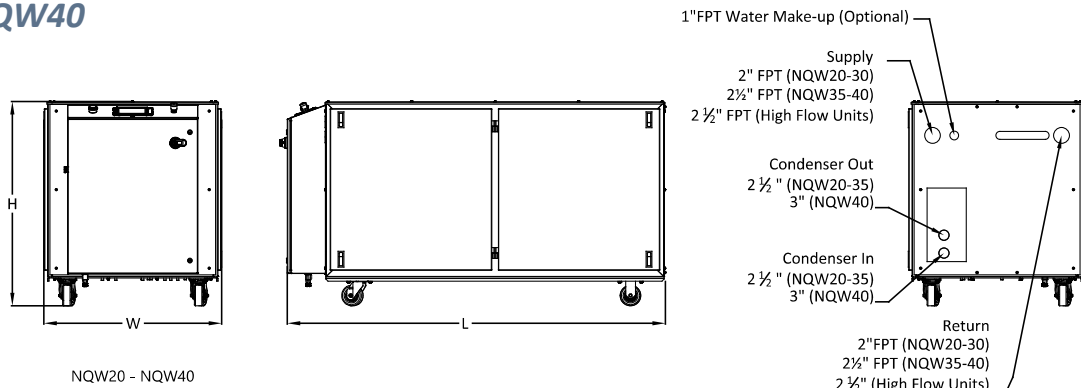

Remote Air Cooled Condenser Chillers	NQR05	NQR08	NQR10	NQR15	NQR20
<b>Cooling Capacity<sup>1</sup></b>	5 tons 18 kW	8 tons 28 kW	11 tons 39 kW	15 tons 53 kW	21 tons 74 kW
<b>Set Point Range</b>	20 to 80°F -7 to 27°C	20 to 80°F -7 to 27°C	20 to 80°F -7 to 27°C	20 to 80°F -7 to 27°C	20 to 80°F -7 to 27°C
<b>Compressor (qty)</b>	1	1	1	1	2
<b>Sound Pressure @ 1 meter (dBA)<sup>2</sup></b>	70	70	71	73	74
<b>Pump Motor Size</b>	2 hp 1.5 kW	2 hp 1.5 kW	3 hp 2.2 kW	3 hp 2.2 kW	5 hp 3.7 kW
<b>Pump Flow</b>	13 gpm 49 lpm	18 gpm 68 lpm	27 gpm 102 lpm	36 gpm 136 lpm	50 gpm 189 lpm
<b>Net Available Pump Pressure<sup>3</sup></b>	40 psi 2.8 bar	41 psi 2.8 bar	48 psi 3.3 bar	40 psi 2.8 bar	44 psi 3.0 bar
<b>Reservoir Holding Capacity</b>	11 gal 42 L	30 gal 114 L	30 gal 114 L	30 gal 114 L	60 gal 227 L
<b>Dimensions L x W x H inch (mm)</b>	48 x 34 x 53 (1,219 x 864 x 1,346)	75 x 34 x 53 (1,905 x 864 x 1,346)	75 x 34 x 53 (1,905 x 864 x 1,346)	75 x 34 x 53 (1,905 x 864 x 1,346)	87 x 41 x 47 (2,210 x 1,041 x 1,194)
<b>Shipping Weight</b>	720 lbs 327 kg	1,195 lbs 542 kg	1,195 lbs 542 kg	1,315 lbs 597 kg	1,900 lbs 862 kg
<b>Operating Weight</b>	810 lbs 367 kg	1,380 lbs 626 kg	1,380 lbs 626 kg	1,500 lbs 680 kg	2,315 lbs 1,050 kg

Remote Air Cooled Condenser Chillers (additional models)	NQR25	NQR30	NQR35	NQR40
<b>Cooling Capacity<sup>1</sup></b>	26 tons 91 kW	31 tons 109 kW	35 tons 123 kW	40 tons 141 kW
<b>Set Point Range</b>	20 to 80°F -7 to 27°C	20 to 80°F -7 to 27°C	20 to 80°F -7 to 27°C	20 to 80°F -7 to 27°C
<b>Compressor (qty)</b>	2	2	2	2
<b>Sound Pressure @ 1 meter (dBA)<sup>2</sup></b>	74	75	77	78
<b>Pump Motor Size</b>	5 hp 3.7 kW	5 hp 3.7 kW	5 hp 3.7 kW	5 hp 3.7 kW
<b>Pump Flow</b>	61 gpm 231 lpm	73 gpm 276 lpm	83 gpm 314 lpm	92 gpm 348 lpm
<b>Net Available Pump Pressure<sup>3</sup></b>	47 psi 3.2 bar	43 psi 2.9 bar	42 psi 2.9 bar	40 psi 2.8 bar
<b>Reservoir Holding Capacity</b>	60 gal 227 L	67 gal 254 L	67 gal 254 L	67 gal 254 L
<b>Dimensions L x W x H inch (mm)</b>	87 x 41 x 47 (2,210 x 1,041 x 1,194)	105 x 41 x 47 (2,667 x 1,041 x 1,194)	105 x 41 x 47 (2,667 x 1,041 x 1,194)	105 x 41 x 47 (2,667 x 1,041 x 1,194)
<b>Shipping Weight</b>	2,100 lbs 953 kg	2,250 lbs 1,021 kg	3,400 lbs 1,542 kg	3,900 lbs 1,769 kg
<b>Operating Weight</b>	2,515 lbs 1,141 kg	2,810 lbs 1,275 kg	3,960 lbs 1,796 kg	4,460 lbs 2,023 kg

<sup>1</sup>Cooling tons based on 12,000 BTU/Hr/ton with 50°F (10°C) leaving coolant and 95°F (35°C) ambient air, R410A or R454B refrigerant.

<sup>2</sup>Sound pressure is for the chiller unit only. See the Remote Air-Cooled Condenser table for remote condenser sound pressures.

<sup>3</sup>Net available pressure at outlet of chiller is pump discharge pressure less the internal pressure loss through the fluid circuit.

## NQR05 - NQR15

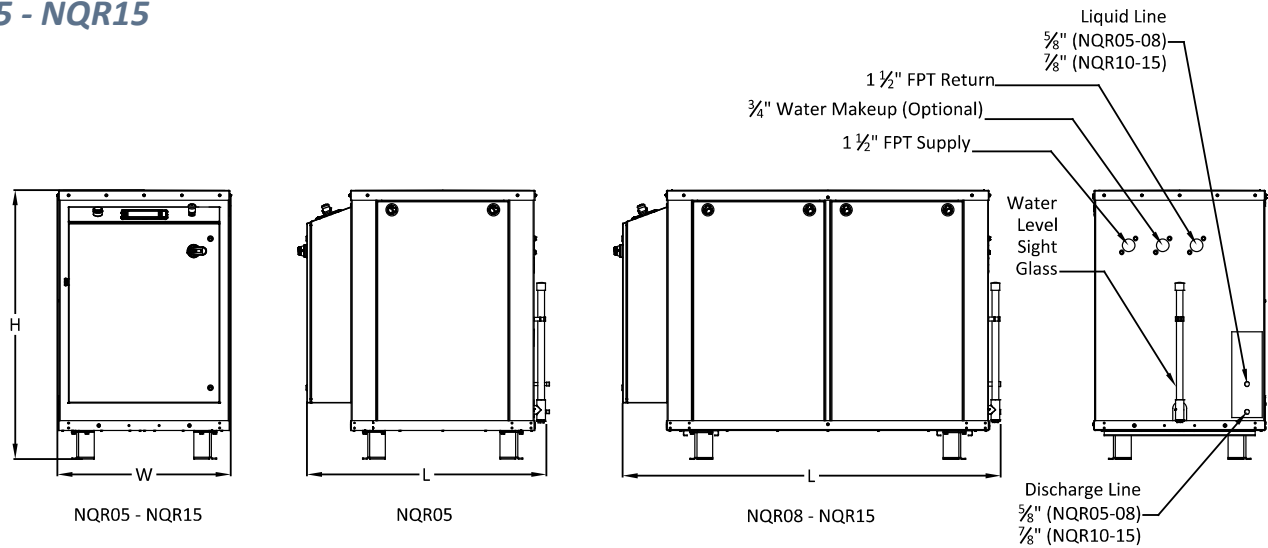

## NQR20 - NQR40

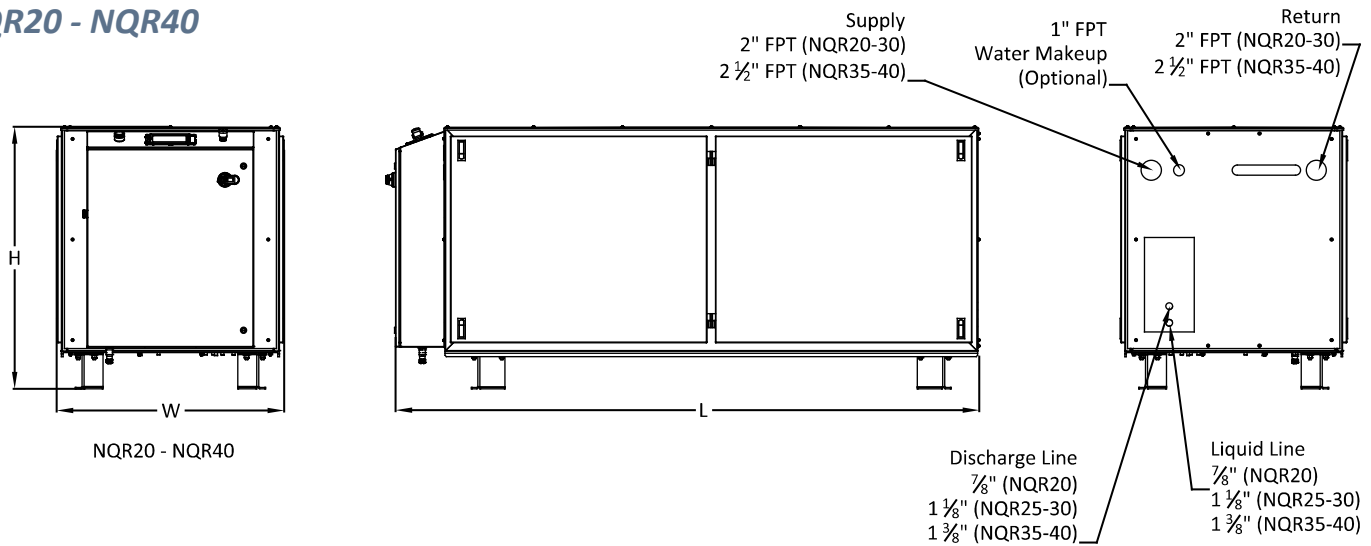

Remote Air Cooled Condensers	KCM009	KCM011	KCM014	KCL023	KCL030
Chiller Used With	NQR05	NQR08	NQR10	NQR15	NQR20
Fans (qty)	1	1	2	2	2
Dimensions L x W x H inch (mm)	54 x 44 x 48 (1,372 x 1,118 x 1,219)	54 x 44 x 48 (1,372 x 1,118 x 1,219)	94 x 44 x 48 (2,388 x 1,118 x 1,219)	126 x 46 x 54 (3,200 x 1,168 x 1,372)	126 x 46 x 54 (3,200 x 1,168 x 1,372)
Shipping Weight	245 lbs 111 kg	265 lbs 120 kg	415 lbs 188 kg	680 lbs 308 kg	720 lbs 327 kg
Operating Weight	Varies based on system charge and operating conditions				

Remote Air Cooled Condensers (additional models)	KCL037	KCL045	KCL054	KCL056
Chiller Used With	NQR25	NQR30	NQR35	NQR40
Fans (qty)	2	3	3	3
Dimensions L x W x H inch (mm)	126 x 46 x 54 (3,200 x 1,168 x 1,372)	181 x 46 x 54 (4,597 x 1,168 x 1,372)	181 x 46 x 54 (4,597 x 1,168 x 1,372)	181 x 46 x 54 (4,597 x 1,168 x 1,372)
Shipping Weight	1,050 lbs 476 kg	1,075 lbs 488 kg	1,175 lbs 533 kg	1,450 lbs 658 kg
Operating Weight	Varies based on system charge and operating conditions			

<sup>1</sup>MCA is Minimum Circuit Amps with standard condenser fan(s) and pump under full load, used for minimum wire size requirement.

<sup>2</sup>MOP is Maximum Overcurrent Protection with standard condenser fans and pump, used for sizing main power protection devices.

### KCM009 & KCM011

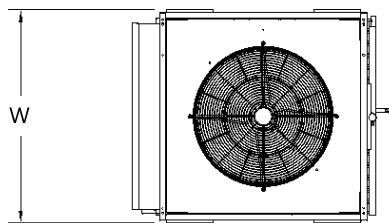

KCM009 used with Model NQR05 chiller  
KCM011 used with Model NQR08 chiller

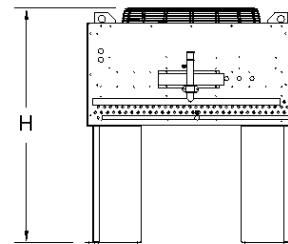
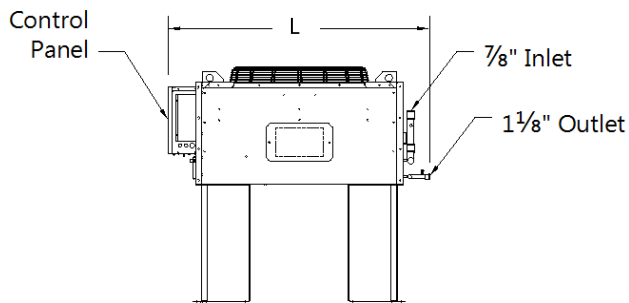

### KCM014

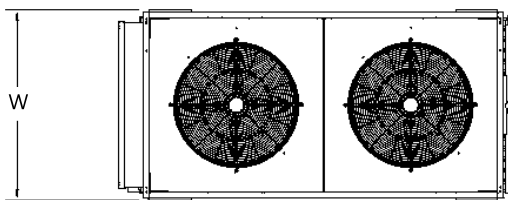

KCM014 used with Model NQR10 chiller

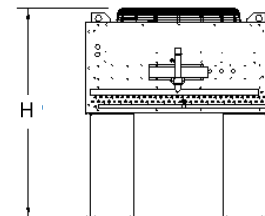
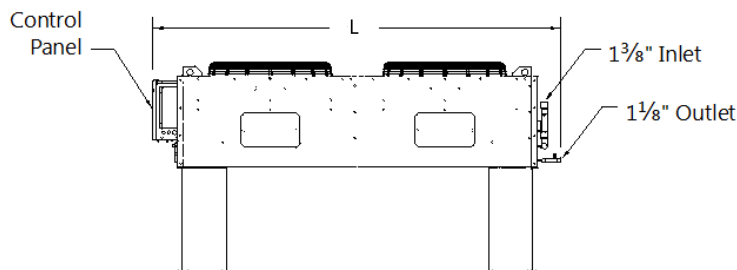

**KCL023, KCL030 & KCL037**

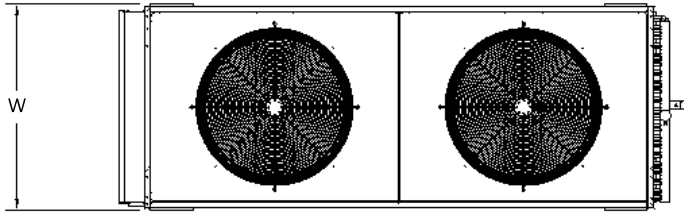

KCL023 used with Model NQR15 chiller  
 KCL030 used with Model NQR20 chiller  
 KCL037 used with Model NQR25 chiller

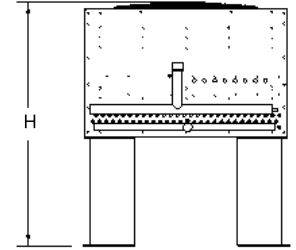
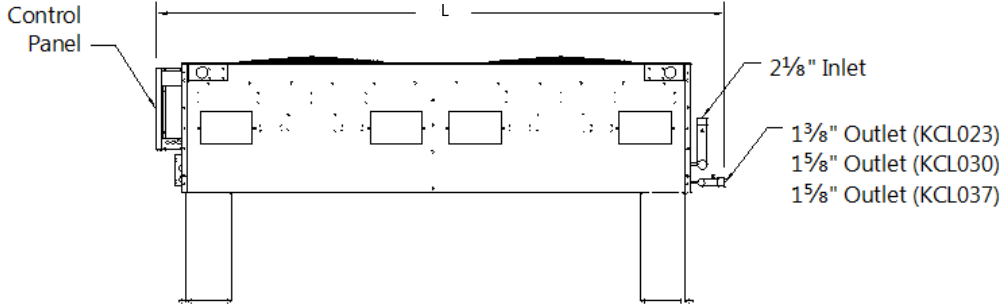

**KCL045, KCL054 & KCL056**

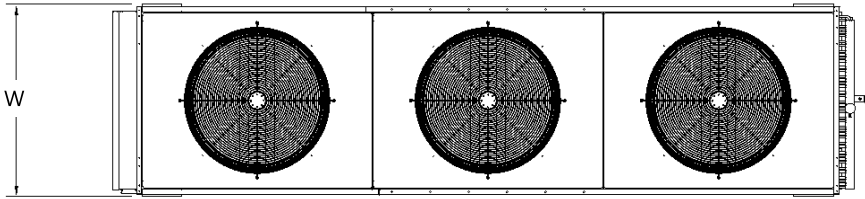

KCL045 used with Model NQR30 chiller  
 KCL054 used with Model NQR35 chiller  
 KCL056 used with Model NQR40 chiller

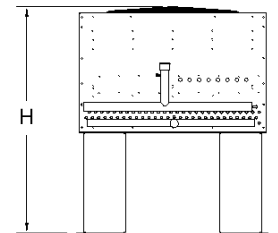
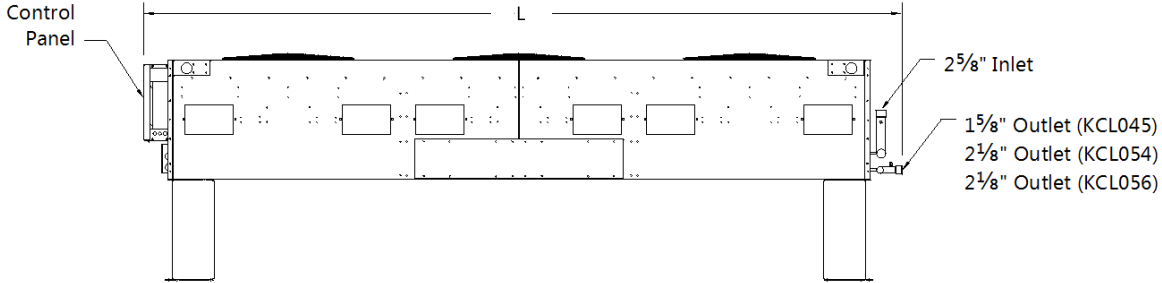

## Electrical Data (60 Hz)

Air Cooled Condenser Chillers	Pump Motor Size	Rated Voltage FLA @ 208		Rated Voltage FLA @ 230		Rated Voltage FLA @ 460		Rated Voltage FLA @ 575	
		MCA <sup>1</sup>	MOP <sup>2</sup>	MCA <sup>1</sup>	MOP <sup>2</sup>	MCA <sup>1</sup>	MOP <sup>2</sup>	MCA <sup>1</sup>	MOP <sup>2</sup>
NQA04	2 hp 1.5 kW	38	60	38	60	18	30	14	25
NQA05	2 hp 1.5 kW	45	70	44	70	22	35	15	25
NQA08	3 hp 2.2 kW	65	100	64	100	30	50	24	40
NQA10	3 hp 2.2 kW	81	150	80	125	36	60	29	50
NQA13	3 hp 2.2 kW	88	150	87	150	41	70	34	60
NQA15	3 hp 2.2 kW	90	150	89	150	47	80	41	70
NQA20	3 hp 2.2 kW	131	175	130	175	64	90	52	70
NQA25	3 hp 2.2 kW	142	200	141	200	73	100	61	90
NQA30	5 hp 3.7 kW	169	225	167	225	88	125	77	110

Water Cooled Condenser Chillers	Pump Motor Size	Rated Voltage FLA @ 208		Rated Voltage FLA @ 230		Rated Voltage FLA @ 460		Rated Voltage FLA @ 575	
		MCA <sup>1</sup>	MOP <sup>2</sup>	MCA <sup>1</sup>	MOP <sup>2</sup>	MCA <sup>1</sup>	MOP <sup>2</sup>	MCA <sup>1</sup>	MOP <sup>2</sup>
NQW05	2 hp 1.5 kW	38	70	37	60	20	35	14	25
NQW08	2 hp 1.5 kW	49	80	48	80	25	45	20	35
NQW10	3 hp 2.2 kW	68	125	67	125	32	60	26	45
NQW15	3 hp 2.2 kW	81	150	80	150	41	70	36	70
NQW20	3 hp 2.2 kW	112	175	111	175	53	80	43	70
NQW25	3 hp 2.2 kW	123	175	122	175	62	90	52	80
NQW30	5 hp 3.7 kW	141	200	139	200	72	100	63	90
NQW35	5 hp 3.7 kW	167	250	165	250	82	125	67	100
NQW40	5 hp 3.7 kW	188	300	186	300	90	150	70	100

Remote Air Cooled Condenser Chillers	Pump Motor Size	Rated Voltage FLA @ 208		Rated Voltage FLA @ 230		Rated Voltage FLA @ 460		Rated Voltage FLA @ 575	
		MCA <sup>1</sup>	MOP <sup>2</sup>	MCA <sup>1</sup>	MOP <sup>2</sup>	MCA <sup>1</sup>	MOP <sup>2</sup>	MCA <sup>1</sup>	MOP <sup>2</sup>
NQR05	2 hp 1.5 kW	38	70	37	60	20	35	14	25
NQR08	2 hp 1.5 kW	49	80	48	80	25	45	20	35
NQR10	3 hp 2.2 kW	68	125	67	125	32	60	26	45
NQR15	3 hp 2.2 kW	81	150	80	150	41	70	36	70
NQR20	3 hp 2.2 kW	112	175	111	175	53	80	43	70
NQR25	3 hp 2.2 kW	123	175	122	175	62	90	52	80
NQR30	5 hp 3.7 kW	141	200	139	200	72	100	63	90
NQR35	5 hp 3.7 kW	167	250	165	250	82	125	67	100
NQR40	5 hp 3.7 kW	188	300	186	300	90	150	70	100

Remote Air Cooled Condensers	Rated Voltage FLA @ 208		Rated Voltage FLA @ 230		Rated Voltage FLA @ 460		Rated Voltage FLA @ 575	
	MCA <sup>1</sup>	MOP <sup>2</sup>	MCA <sup>1</sup>	MOP <sup>2</sup>	MCA <sup>1</sup>	MOP <sup>2</sup>	MCA <sup>1</sup>	MOP <sup>2</sup>
KCM009	2.9	15	2.9	15	1.4	15	1.1	15
KCM011	2.9	15	2.9	15	1.4	15	1.1	15
KCM014	5.2	15	5.2	15	2.6	15	1.8	15
KCL023	16.0	20	16.0	20	7.0	15	5.6	15
KCL030	16.0	20	16.0	20	7.0	15	5.6	15
KCL037	16.0	20	16.0	20	7.0	15	5.6	15
KCL045	21.5	25	21.5	25	10.1	15	8.1	15
KCL054	21.5	25	21.5	25	10.1	15	8.1	15
KCL056	21.5	25	21.5	25	10.1	15	8.1	15

<sup>1</sup>MCA is Minimum Circuit Amps, used for minimum wire size requirement.

<sup>2</sup>MOP is Maximum Overcurrent Protection, used for sizing main power protection device.

## Pump Curves<sup>4</sup> Based on Water at 50°F (10°C), 60 Hz

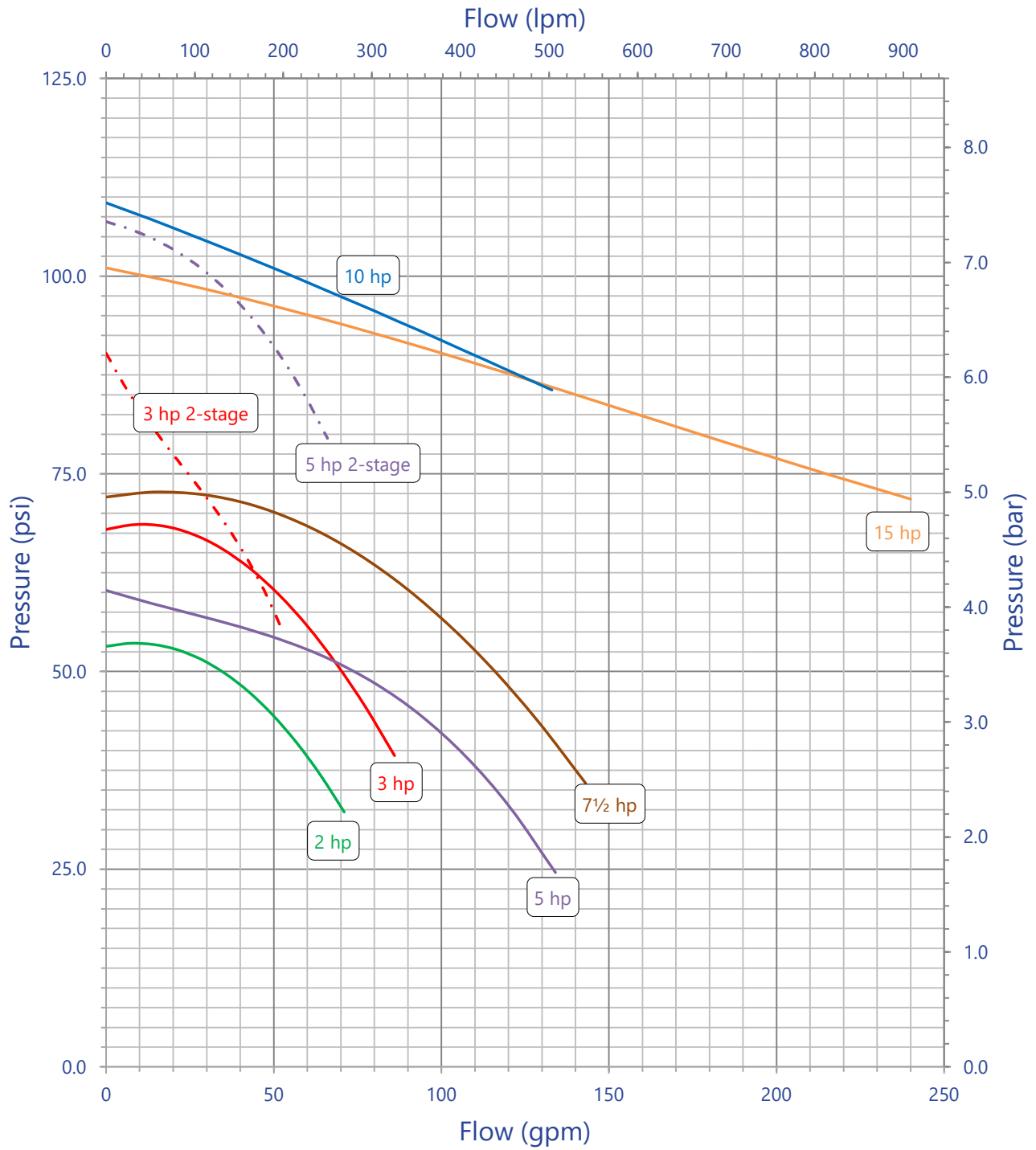

<sup>4</sup>See product catalog for net pump performance curves.



**Thermal Care is ISO 9001 Certified**  
 Manufacturer reserves the right to change specification  
 or design without notification or obligation.

