

Accuchiller NQV Series

5-30 ton Portable and Packaged Industrial Chillers

Benefits:

- Direct Drive Scroll Compressors:** Hermetically sealed scroll compressors with proven performance in industrial cooling for reliable, low maintenance, and efficient operation.
- Stainless Steel Evaporators:** High efficiency stainless steel plates with copper brazing provide maximum performance, long life, and an enhanced level of protection from harsh process conditions.
- Stainless Steel Pump:** Selected for peak performance with the utmost in corrosion protection to ensure a long useful life under severe industrial conditions.
- Nonferrous Reservoir and Water Lines:** Insulated reservoir, fluid lines, pumps, and other components in the process fluid circuit will remain free of rust for maximum corrosion protection.
- Evaporator Inlet Strainer:** Removes any debris present in the process fluid to prevent costly downtime and repair due to a clogged chiller evaporator.
- Easy Access Cabinet:** Heavy-gauge machine access doors with industrial grade tools-free latches provide quick access to all components for easy operation and maintenance.
- Compressor Protection Technology:** Variable-speed compressor soft-start technology allows limitless on/off cycles and uses start-to-start anti-recycle control logic to limit cycling under low-load operating conditions to extend compressor life.
- Warranty:** 18 months parts on entire unit; 12 months labor.



The Accuchiller NQ Series, known for its exceptional performance, now offers an optional variable-speed compressor upgrade - the NQV Series. This innovative feature significantly reduces energy costs by precisely adjusting cooling output to meet real-time demand.

Chillers often operate below their full capacity, which reduces energy efficiency. Traditional fixed-speed compressors rely on hot gas bypass valves to simulate a full load, leading to inefficiencies at part-load conditions. The NQV Series, with its variable-speed scroll compressors, provides a more

efficient solution by adjusting the speed to match the actual cooling demand. Combined with a user-friendly premium PLC control system, it ensures optimal performance and lower operating costs.

NQV Series chillers are available in air cooled or water cooled options. Each model is packed with innovative features that optimize performance and reliability. These features include scroll compressors, microchannel condensers, stainless steel brazed plate evaporators, and low-noise ensure smooth operation and energy savings.

Benefits of the NQV Series Industrial Chiller Features:

VARIABLE SPEED FANS

Save energy while moving more air and reducing noise levels.

NEW! HOT SHELL COMPRESSORS

Extends operating range, boosts reliability and ensures lubrication of the bearings under varying loads, enhances energy efficiency, maintains proper refrigerant flow for consistent cooling under variable load/ambient conditions.

REMOVABLE AND CLEANABLE FILTERS

Protects the internal components of the chiller.

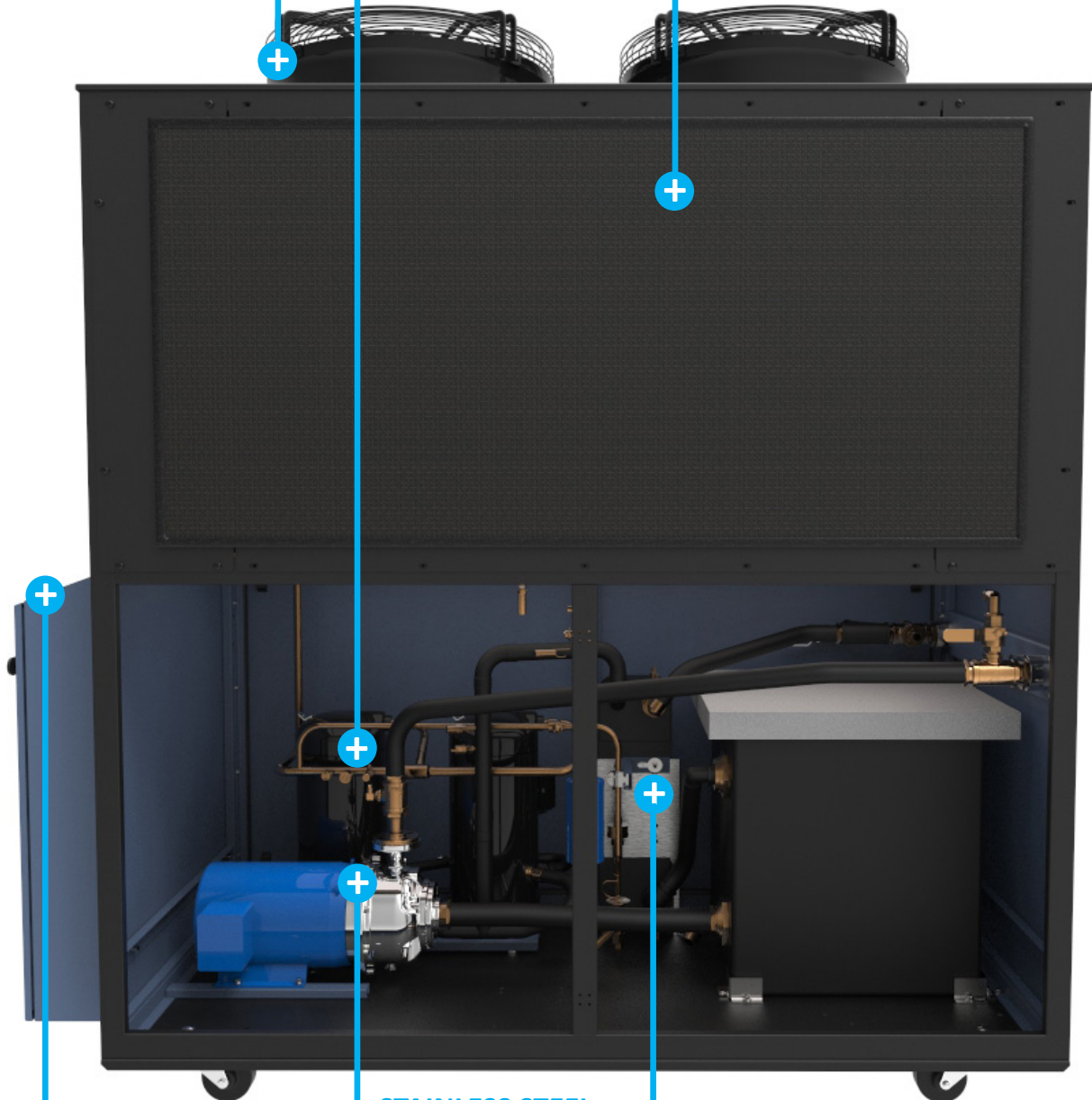

7-INCH COLOR TOUCH SCREEN

Allows monitoring of chiller operation and easy set point control.

STAINLESS STEEL PROCESS PUMP

Use of premium components provide protection against rust and corrosion for reliability and long life.

NEW! DUAL REFRIGERATION CIRCUIT

Provides redundancy and reliability, better matches varying cooling loads for energy efficiency, provides faster pull-down times of process fluid, offers higher capacity in a compact mobile design, and allows for service flexibility on 20-ton and above models.

Additional Benefits:

- **Premium Control Panel:** Available C-UL 508A industrial control panel with high-quality components that are safe and built to last.
- **Compressor and Pump Run Hour Displays:** Monitor compressor and pump running hours to assist with scheduling maintenance.
- **Power Monitor:** Protects the chiller from extensive damage to the compressor and pump due to loss of phase or phase reversal in the main supply.
- **Reservoir Low Level Alarm:** Indicates a low process fluid condition and protects the process pump and chiller from damage caused by a critically low operating level in the reservoir.
- **Master Reset:** Quick and easy way to reset and restore the control system to factory default settings if a control parameter is mistakenly changed.
- **High-Quality 24 VDC Power Supply:** The 24-volt DC power supply ensures dependable control circuit power and isolates the control circuit from static interference to ensure stable and precise operation.
- **Internal Valve Bypass Line:** Protects against low or no flow through the evaporator due to varying process flow requirements and evaporator damage due to freezing and/or pump damage and nuisance low flow alarms.
- **Industrial Grade Casters:** Makes moving this portable chiller easy.

Available Options:

- High flow/high pressure pumps
- High flow unit design
- Alarm horn
- Alarm relay
- Rotary non-fused or fused disconnect switch
- C-UL508A industrial control panel construction
- Outdoor-duty construction
- Indoor duty low temperature (0°F to 120°F; -18°C to 49°C)
- Outdoor duty temperature (-20°F to 120°F; -29°C to 49°C)
- Air-cooled condenser coil coating for coastal regions
- Pump and tank deduct
- Oversized reservoirs
- Stainless steel cabinetry
- Automatic electric water make-up valve
- High pressure fans for ducting of discharge air
- Emergency stop button
- Remote HMI with 50 foot wire
- Special color paint
- CONNEX 4.0 system-wide control
- 5 year compressor parts warranty

7-Inch Color Touch Screen

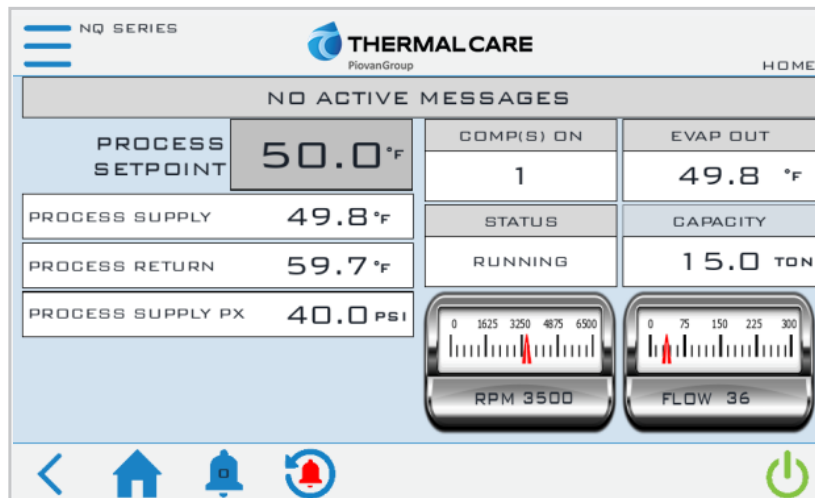





Home Screen

Unsure If A Variable Speed Chiller Is Right For You?

Let's explore the differences between the NQV Series (variable speed) and the standard NQ Series (fixed speed) chiller! Ask yourself:

- Does your application have varying cooling demands?
- Do you value energy efficiency and cost savings?
- Does your process require precise, stable temperature control?
- If you answered "YES" to any of the above, the NQV Series is the smart move for your operation.

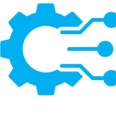
Description of Features	NQV Series Variable Speed Chiller (especially at partial load)	NQ Series Fixed Speed Chiller (especially at partial load)	Important Tips and Details
 Energy Efficiency	Adjusts compressor speed to match the cooling demand in real time. When full capacity isn't needed, the system ramps down — drastically reducing energy usages.	Always runs at full speed, even if the application does not require it. This leads to higher energy consumption, especially in applications with fluctuating demands.	Did you know that chillers spend most of their operating life under partial load? Reducing compressor motor speed by just 20% can cut energy usage by over 50%.
 Precision Temperature Control	Able to quickly respond to sudden changes in process loads while maintaining precise fluid temperatures – ideal for presses that are sensitive to temperature fluctuations (e.g., plastics, medical, or high-tech manufacturing).	Maintains temperature through use of hot gas bypass and/or compressor cycling, reacts slower to process load changes which can result in temporary fluid temperature fluctuations.	Pro Tip: Think of it like a dimmer switch versus a light switch. NQV modulates smoothly; the NQ simply toggles on or off, at 100%.
 Reduction of Noise	Runs 25% quieter and has reduced inrush current starts reduce compressor motor stress.	Louder under full speed operation and has high inrush current starts which can shorten the life of the compressor.	Did you know that variable speed compressors offer 15-20 dB(A) reduction in noise level compared to their fixed-speed counterparts?
 Lower Operating Cost Over Time	While it may have a higher upfront cost, energy savings and lower maintenance can lead to a fast ROI — often under a year.	Lower initial investment, but higher energy bills and more repairs over time.	Pro Tip: When investing in capital equipment, consider the total cost of ownership, calculating energy savings into the equation. The ROI may surprise you.
 Extended Equipment Life	Soft starts and consistent operation reduce wear on major components like compressors and pumps. This compressor slowly ramps up and down, versus the bang on/bang off of a traditional scroll.	Frequent start-stop cycles contribute to faster wear.	Fact: Soft start offers 2-3x longer life for internal components.
 Smart Integration and Controls	Comes standard with our advanced PLC control platform, offering features like real-time energy monitoring, trend tracking, and remote connectivity. Ideal for Industry 4.0 and smart factory integration.	Reliable controls, but fewer built-in monitoring and integration features.	Always watching: Remote connectivity allows you to monitor system activity in real time — without being on the plant floor.

Control Features

Description of Functions	Premium Controls
Display Parameters	
Process Fluid Supply and Return Temperatures	●
Evaporator Fluid Leaving Temperature	●
Process Fluid Supply Pressure	●
Compressor Running Hours	●
Pump Running Hours	●
Condenser Fan Running Hours	●
Refrigerant Suction Pressure	●
Refrigerant Suction Temperature and Superheat	●
Refrigerant Liquid Temperature and Subcooling	●
Refrigeration Discharge Pressure	●
Refrigerant Discharge Temperature	●
Alarms and Warnings	
High Process Fluid Temperature	●
Low Process Fluid Temperature	●
Evaporator Fluid Freeze	●
Evaporator Fluid Low Flow	●
Refrigerant High Pressure	●
Refrigerant Low Pressure	●
Compressor Overload	●
Pump Overload	●
Condenser Fan Overload	●
Reservoir Low Level	●
Communications and Remote Interfaces	
Process Fluid Supply Temperature (0-10 VDC)	●
Remote Start / Stop	●
Alarm Contact	●
CONNEX4.0 Ready	●
Modbus RTU	●
Modbus TCP / IP	●
BACnet MS / TP	○
BACnet / IP	○

Legend: Standard = ● Optional = ○

Energy Savings

ROI in under a year: Available variable speed scroll compressor technology, in conjunction with a PLC, constantly monitors the process load and adjusts the compressor speed for peak for peak efficiency and temperature control. By automatically adjusting the compressor speed, the chiller works only as hard as necessary to provide optimum performance with significantly reduced power use. The chiller can pay for itself in as little as one year.

Variable-Speed Compressor Payback (Years)¹

Capacity	Hours	Process Load (Percentage of Full Capacity)							
		50%	55%	60%	65%	70%	75%	80%	85%
5 Tons 18 kW	4,000	2.5	2.7	2.9	3.2	3.6	4.3	5.4	7.6
	6,000	1.7	1.8	1.9	2.1	2.4	2.9	3.6	5.0
	8,400	1.2	1.3	1.4	1.5	1.7	2.0	2.6	3.6
10 Tons 35 kW	4,000	1.1	1.2	1.3	1.4	1.6	1.9	2.4	3.3
	6,000	0.7	0.8	0.8	0.9	1.1	0.3	1.6	2.2
	8,400	0.5	0.6	0.6	0.7	0.8	0.9	1.1	1.6
15 Tons 53 kW	4,000	0.9	0.9	1.0	1.1	1.2	1.5	1.9	2.6
	6,000	0.6	0.6	0.7	0.7	0.8	1.0	1.2	1.7
	8,400	0.4	0.4	0.5	0.5	0.6	0.7	0.9	1.2
20 Tons 70 kW	4,000	0.8	0.8	0.9	1.0	1.1	1.3	1.5	2.1
	6,000	0.5	0.5	0.6	0.6	0.7	0.8	1.0	1.4
	8,400	0.4	0.4	0.4	0.5	0.5	0.6	0.7	1.0
30 Tons 106 kW	4,000	0.6	0.6	0.7	0.7	0.8	1.0	1.2	1.6
	6,000	0.4	0.4	0.4	0.5	0.6	0.6	0.8	1.1
	8,400	0.3	0.3	0.3	0.3	0.4	0.5	0.6	0.8

¹Based on \$0.10/kWhr power cost

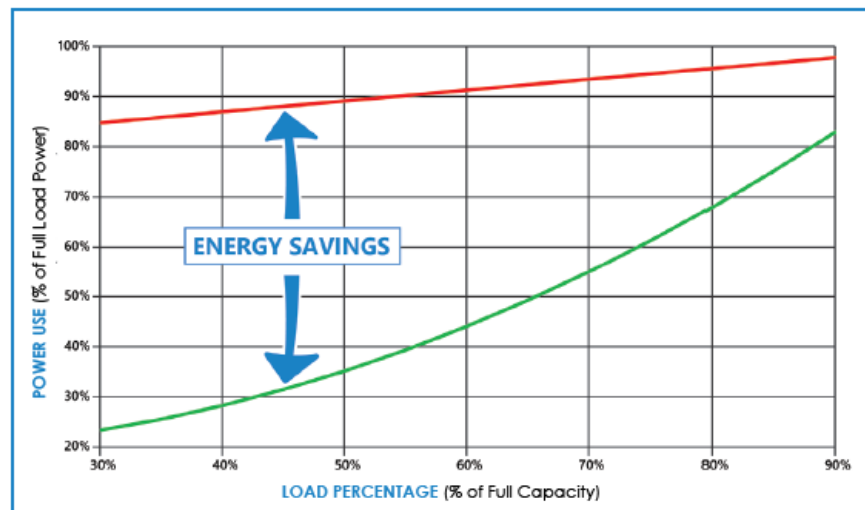

- Fixed Speed Scroll Compressor
- Variable Speed Scroll Compressor

Technical Data

Air Cooled Condenser Chillers	NQVA05	NQVA10	NQVA15	NQVA20	NQVA30
Cooling Capacity ¹	5 tons 18 kW	11 tons 39 kW	15 tons 53 kW	21 tons 74 kW	31 tons 109 kW
Set Point Range	20 to 80°F -7 to 27°C	20 to 80°F -7 to 27°C	20 to 80°F -7 to 27°C	20 to 80°F -7 to 27°C	20 to 80°F -7 to 27°C
Compressor (qty)	1	1	1	2	2
Sound Pressure @ 1 meter (dBA)	74	76	82	84	86
Pump Motor Size	2 hp 1.5 kW	3 hp 2.2 kW	3 hp 2.2 kW	5 hp 3.7 kW	5 hp 3.7 kW
Pump Flow	12 gpm 45 lpm	27 gpm 102 lpm	36 gpm 136 lpm	48 gpm 182 lpm	72 gpm 273 lpm
Net Available Pump Pressure ²	41 psi 2.8 bar	48 psi 3.3 bar	40 psi 2.8 bar	45 psi 3.1 bar	43 psi 3.0 bar
Reservoir Holding Capacity	14 gal 53 L	30 gal 114 L	60 gal 227 L	60 gal 227 L	67 gal 254 L
Dimensions L x W x H in (mm)	48 x 34 x 61 (1,219 x 864 x 1,549)	75 x 34 x 61 (1,905 x 864 x 1,549)	87 x 41 x 94 (2,210 x 1,041 x 2,388)	87 x 41 x 94 (2,210 x 1,041 x 2,388)	105 x 41 x 94 (2,667 x 1,041 x 2,388)
Shipping Weight	770 lbs 349 kg	1,245 lbs 565 kg	3,250 lbs 1,474 kg	3,350 lbs 1,520 kg	4,200 lbs 1,905 kg
Operating Weight	860 lbs 390 kg	1,420 lbs 644 kg	3,585 lbs 1,626 kg	3,765 lbs 1,708 kg	4,760 lbs 2,159 kg

NQVA05 - NQVA10

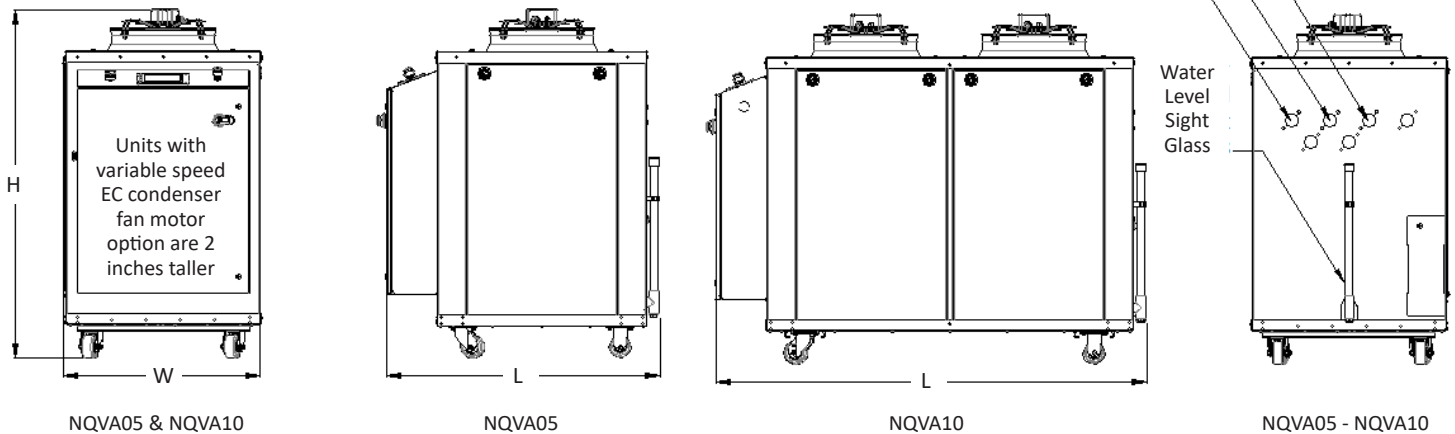

NQVA15 - NQVA30

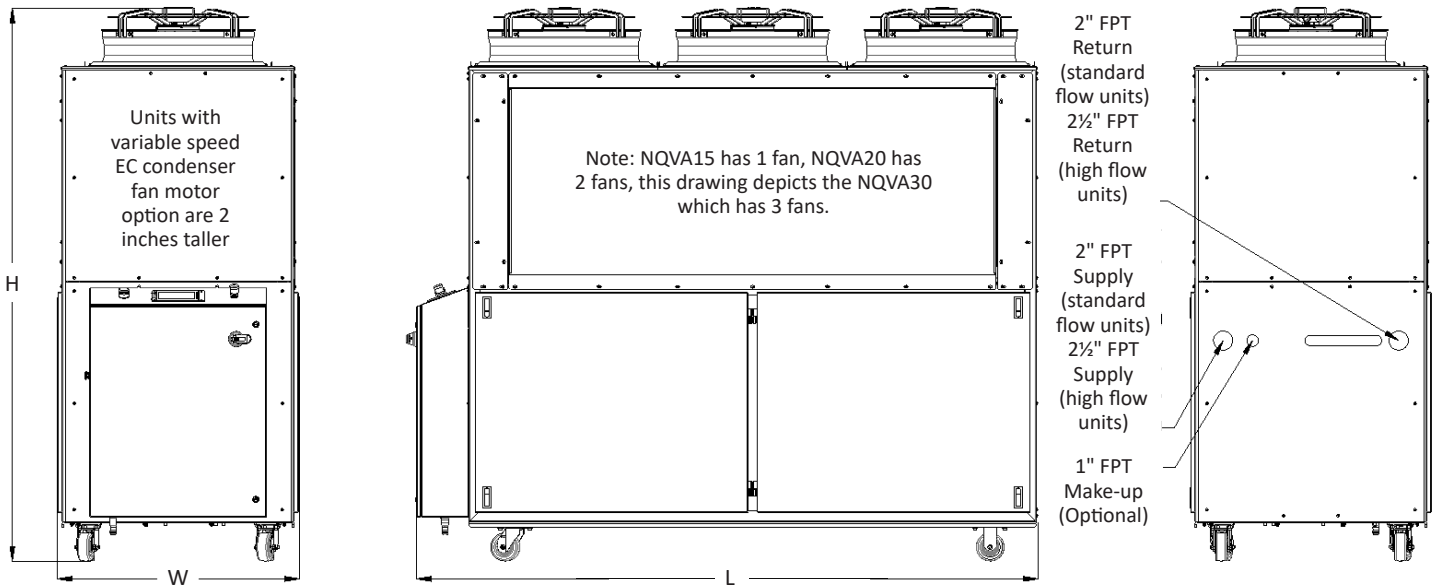

Water Cooled Condenser Chillers	NQVW05	NQVW10	NQVW15	NQVW20	NQVW30
Cooling Capacity¹	6 tons 21 kW	12 tons 42 kW	17 tons 60 kW	23 tons 81 kW	33 tons 116 kW
Set Point Range	20 to 80°F -7 to 27°C	20 to 80°F -7 to 27°C	20 to 80°F -7 to 27°C	20 to 80°F -7 to 27°C	20 to 80°F -7 to 27°C
Compressor (qty)	1	1	1	2	2
Sound Pressure @ 1 meter (dBA)	70	71	73	74	75
Pump Motor Size	2 hp 1.5 kW	3 hp 2.2 kW	3 hp 2.2 kW	5 hp 3.7 kW	5 hp 3.7 kW
Pump Flow	13 gpm 49 lpm	29 gpm 110 lpm	39 gpm 148 lpm	54 gpm 204 lpm	79 gpm 299 lpm
Net Available Pump Pressure²	40 psi 2.8 bar	46 psi 3.2 bar	35 psi 2.4 bar	41 psi 2.8 bar	39 psi 2.7 bar
Reservoir Holding Capacity	14 gal 53 L	30 gal 114 L	30 gal 114 L	60 gal 227 L	67 gal 254 L
Dimensions L x W x H in (mm)	48 x 34 x 53 (1,219 x 864 x 1,346)	75 x 34 x 53 (1,905 x 864 x 1,346)	75 x 34 x 53 (1,905 x 864 x 1,346)	87 x 41 x 47 (2,210 x 1,041 x 1,194)	105 x 41 x 47 (2,667 x 1,041 x 1,194)
Shipping Weight	770 lbs 349 kg	1,245 lbs 565 kg	1,365 lbs 619 kg	1,950 lbs 885 kg	2,300 lbs 1,043 kg
Operating Weight	860 lbs 390 kg	1,420 lbs 644 kg	1,550 lbs 703 kg	2,365 lbs 1,073 kg	2,860 lbs 1,297 kg

¹Cooling tons based on 12,000 BTU/Hr/ton with 50°F (10°C) leaving coolant, 85°F (29°C) condenser water or 95°F (35°C) ambient air and R410A refrigerant.

²Net available pressure at outlet of chiller is pump discharge pressure less the internal pressure loss through the fluid circuit.

NQVW05 - NQVW15

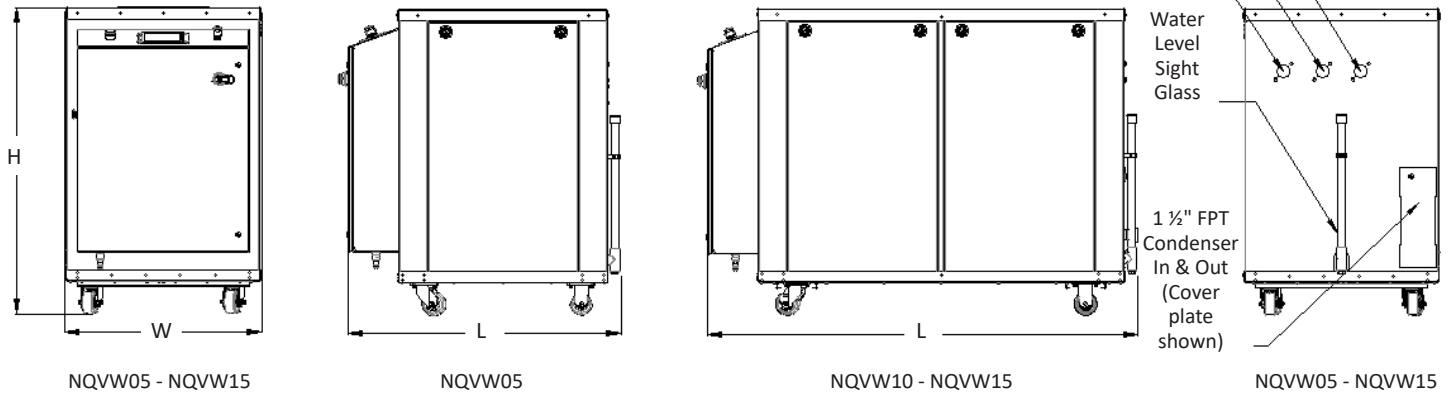

NQVW20 - NQVW30

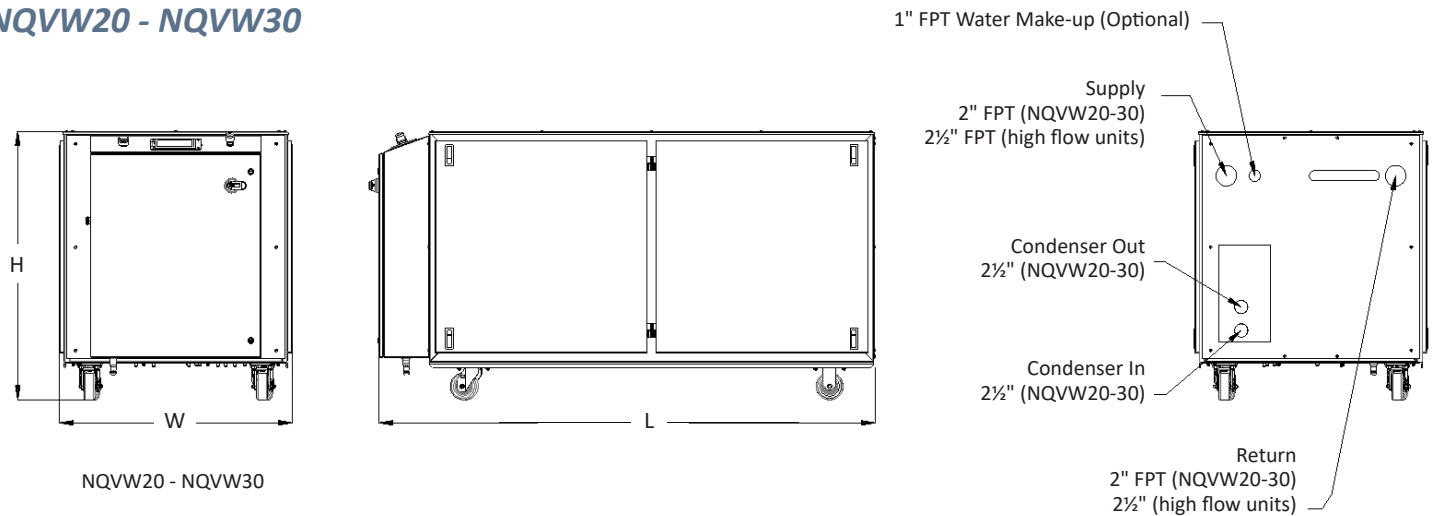

Electrical Data

Air Cooled Condenser Chillers	Rated Voltage ¹ FLA @ 208		Rated Voltage ¹ FLA @ 230		Rated Voltage ¹ FLA @ 460		Rated Voltage ¹ FLA @ 575	
	MCA ²	MOP ³	MCA ²	MOP ³	MCA ²	MOP ³	MCA ²	MOP ³
NQVA05	N/A	N/A	57	100	29	50	Contact Factory	
NQVA10	N/A	N/A	105	200	53	90		
NQVA15	N/A	N/A	N/A	N/A	82	150		
NQVA20	N/A	N/A	186	300	94	150		
NQVA30	N/A	N/A	N/A	N/A	151	225		

¹Allowable voltage is $\pm 10\%$ from rated voltage.

²MCA is Minimum Circuit Amps with standard condenser fan(s) and pump under full load, used for minimum wire size requirement.

³MOP is Maximum Overcurrent Protection with standard condenser fans(s) and pump, used for sizing main power protection devices.

Water Cooled Condenser Chillers	Rated Voltage ¹ FLA @ 208		Rated Voltage ¹ FLA @ 230		Rated Voltage ¹ FLA @ 460		Rated Voltage ¹ FLA @ 575	
	MCA ²	MOP ³	MCA ²	MOP ³	MCA ²	MOP ³	MCA ²	MOP ³
NQVW05	N/A	N/A	54	100	27	50	Contact Factory	
NQVW10	N/A	N/A	105	200	50	90		
NQVW15	N/A	N/A	N/A	N/A	77	150		
NQVW20	N/A	N/A	170	250	85	125		
NQVW30	N/A	N/A	N/A	N/A	137	200		

¹Allowable voltage is $\pm 10\%$ from rated voltage.

²MCA is Minimum Circuit Amps with standard chillers under full load, used for wire size requirements.

³MOP is Maximum Overcurrent Protection with standard configuration chillers, used for sizing main power protection devices.

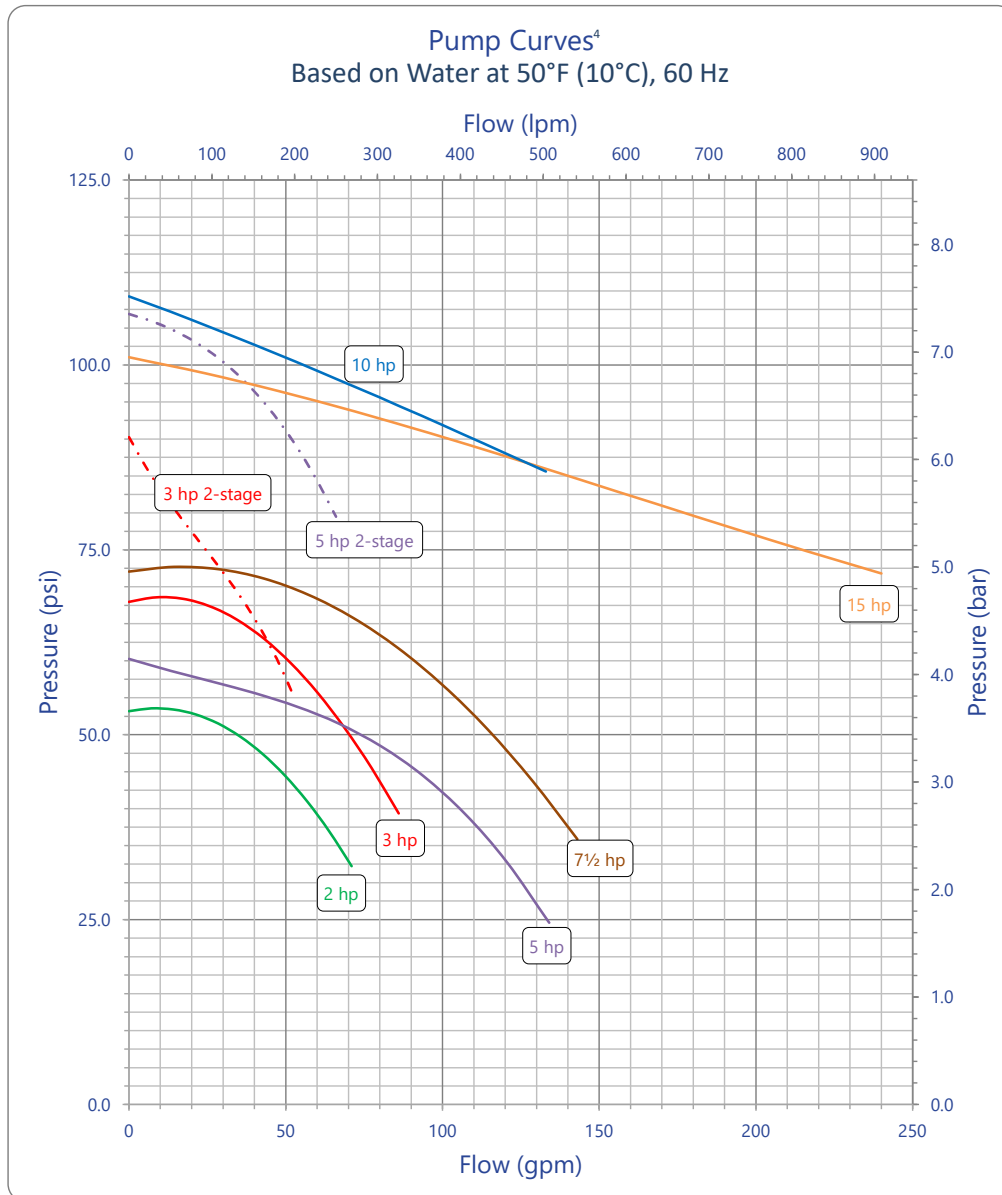

⁴See product catalog for net pump performance curves.



Thermal Care is ISO 9001 Certified
Manufacturer reserves the right to change specification or design without notification or obligation.

