

Accuchiller TCFW375 Series

Central Chiller

Benefits:

- **Lower Global Warming Potential*:** Featuring Opteon™ XP10 (R-513A) Refrigerant with low toxicity and low flammability.
- **Variable-Speed Compressor:** Direct drive variable-speed centrifugal compressor technology continuously adjusts speed to match load to reduce operating costs.
- **Magnetic Bearing:** A magnetic field levitates the drive shaft and eliminates the friction of conventional bearings for higher efficiencies and an oil-free refrigeration system.
- **Integral Variable Speed Drive:** High efficiency brushless DC motor with built-in variable-speed drive technology is refrigerant cooled, compact, and energy efficient.
- **Soft Start:** The variable-speed drive limits soft-starts to 2 amps inrush current per compressor to reduce peak energy demand and extend compressor motor life.
- **Low Noise Operation:** The magnetic bearings keep the drive shaft in position under high-speed operation for virtually no structural vibration and low noise.
- **Rotary Circuit Breaker:** A through-the-door rotary circuit breaker allows easy maintenance of the chiller.
- **Warranty:** 1 year parts and labor.



Thermal Care is at the forefront of process cooling technology. TC Series industrial central chillers feature revolutionary, frictionless, magnetic bearing Turbocor compressors for optimal performance and unmatched part load efficiency. The oil-free design eliminates oil management systems, reducing costs and environmental impact while enhancing reliability.

Specifically designed for ice rink applications, the TCFW375 combines the efficiencies of a hybrid film evaporator with the advanced Turbocor TTH375 high lift variable speed centrifugal compressor, consistently achieving 10°F (-12°C) fluid temperatures. These proven technologies provide precise temperature control, adaptability

to varying loads and optimal full and part load efficiencies, all while significantly reducing energy consumption. After the ice is formed, the chiller maintains a stable temperature of 15°F (-9°C) by reducing compressor speed, which further decreases energy consumption.

TCF Series chillers feature an intuitive PLC system with a 7" HMI high resolution LCD color touch screen for precise control and monitoring. The user-friendly interface provides real-time system data, allowing users to monitor system operating conditions, adjust parameters, and troubleshoot with ease.

Discover how the TC Series can revolutionize your process cooling operations.

*In comparison to HCFC-22 | NHL AND THE NHL SHIELD ARE REGISTERED TRADEMARKS OF THE NATIONAL HOCKEY LEAGUE. ©NHL 2022. ALL RIGHTS RESERVED.

Benefits of the TCFW375 Series Industrial Chiller Features:

MAGNETIC BEARING

A magnetic field levitates the drive shaft and eliminates friction and noise. No more conventional bearings!

HYBRID FILM EVAPORATOR

Provides the most efficient heat transfer, while minimizing refrigerant charge requirements.

VARIABLE SPEED COMPRESSOR

Direct-drive centrifugal compressor continuously adjusts speed to match load - reducing energy consumption.

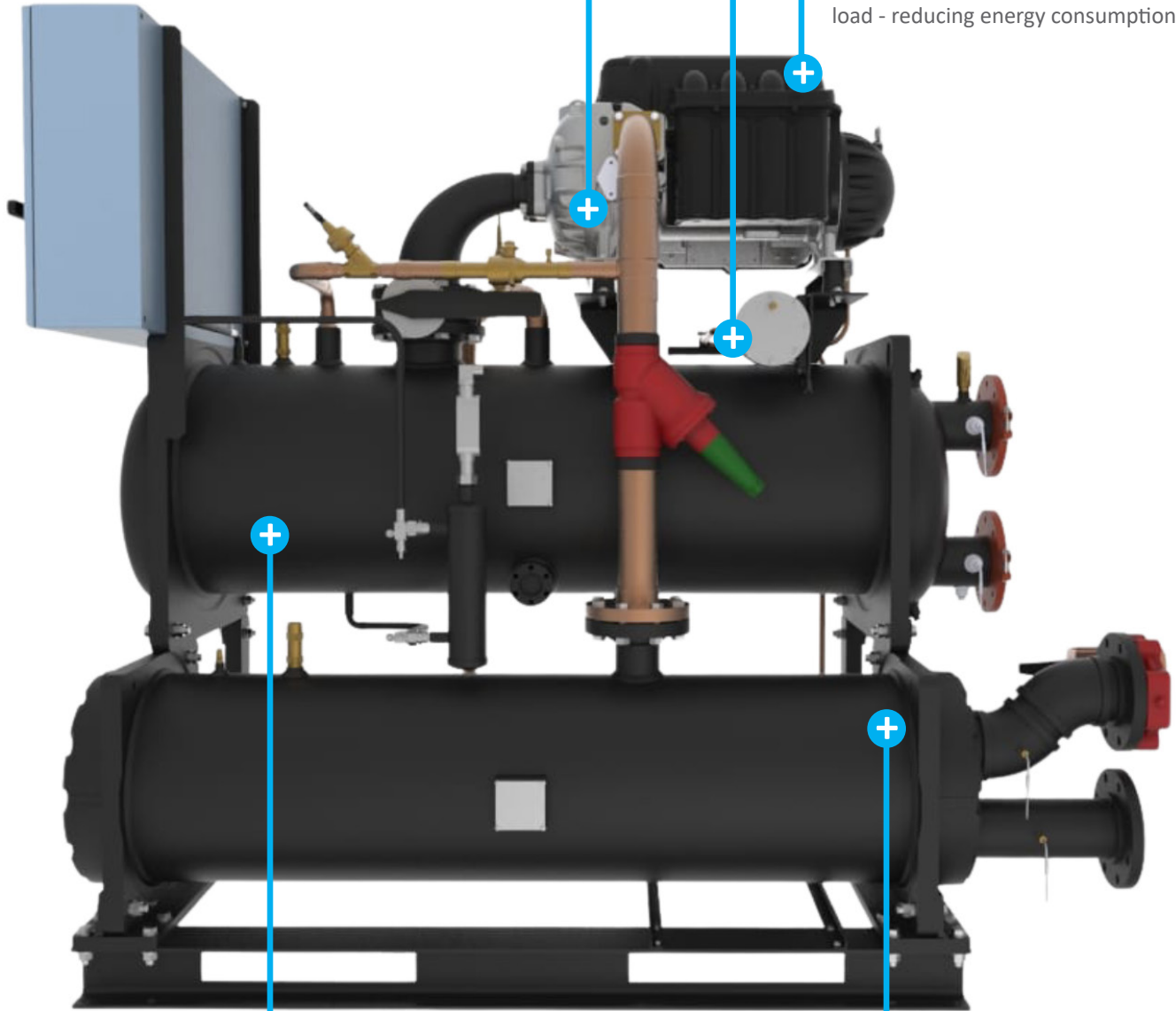

OPTEON™ XP10 (R-513A) REFRIGERANT

Low GWP refrigerant, with low toxicity and low flammability. Approved for use in public spaces.

MODULAR EXPANDABLE SYSTEM

Flexible system design, with expansion capabilities up to over 600 tons, using up to six chillers.

Additional Benefits:

- **UL 508A Industrial Control Panel:** Every chiller has a UL label certifying the panel design and components comply with UL 508A standards ensuring the panels are safe and consistent for reliable operation.
- **Hybrid Film Evaporator:** Advanced design provides the most efficient heat transfer while minimizing the refrigerant charge requirement results in a compact, extremely energy-efficient unit.
- **Slim Footprint:** Unit has a slim design and can fit through a 34" (864 mm) opening.
- **Advanced Controls with Color Touch Screen:** 7-inch color touch screen shows chiller operation for quick and easy monitoring and control of the system. Can control up to six chillers.

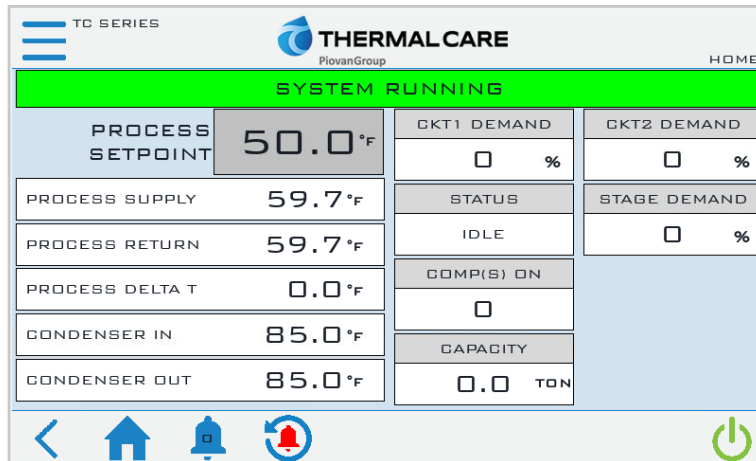

- **CONNEX4.0 Ready Controls:** Equipped with an Ethernet port and is fully compatible with the CONNEX4.0 plant-wide equipment control and monitoring system.
- **Modular Expandable System:** Allows for flexible system design and provides for system expansion to over 300 tons (1,055 kW) using up to six chillers.

Available Option:

- **BACnet Communications Port:** Adds a Modbus to BACnet gateway wired to a RS-485 connector on the control panel.

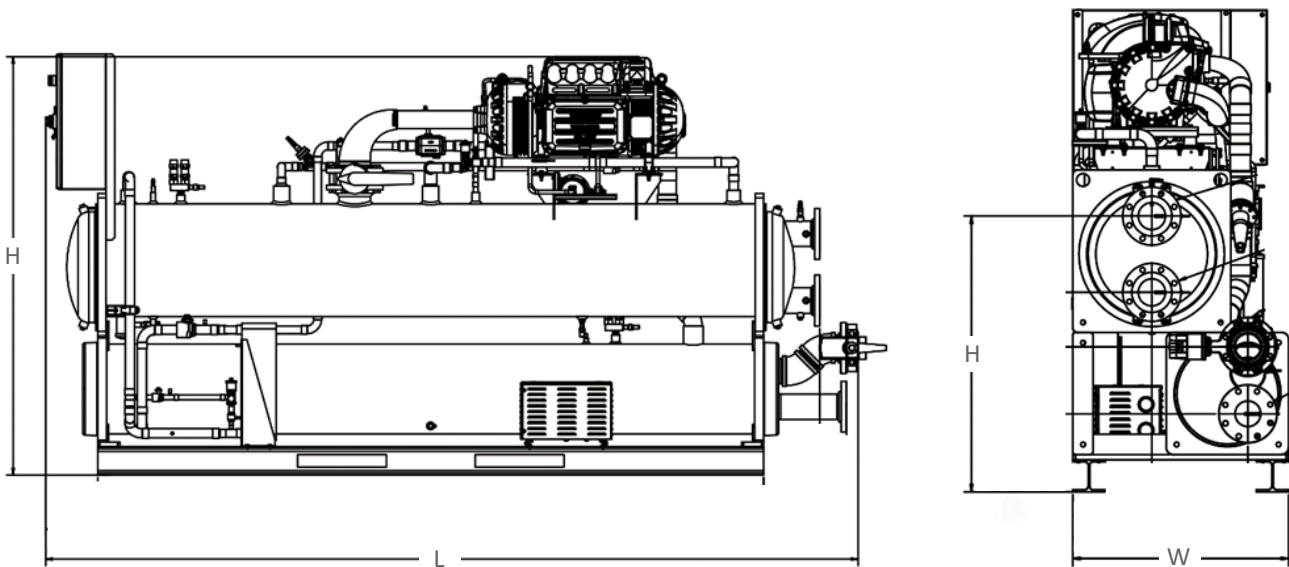

Technical Data

TCFW375	
Cooling Capacity Range ¹	45 to 55 tons (158 to 193 kW)
Nominal Capacity (ton)	50 tons (176 kW)
Set Point Range	10 to 55°F (-12° to -4°C)
Intended Operating Range	10 to 15°F (-12° to -9°C)
Compressor (qty)	1
Condenser Water Inlet and Outlet Flange (in)	4
Process Fluid Inlet and Outlet Flange (in)	4
Process Fluid	40% ethylene glycol
Evaporator Flow @ 10°/15°F (-12°/-9°C)	467/427 gpm (1,768/1,616 lpm)
Dimensions L x W x H inch (mm)	144 x 33 x 74 (2,210 x 914 x 1,880)
Shipping Weight	5,600 lbs (2,540 kg)
Operating Weight	6,000 lbs (2,722 kg)

¹Cooling capacity when cooling water with 13°F (-16°C) set point, 16°F (-9°C) return, 85°F (29°C) condenser water, R513A refrigerant.

Electrical Data

Model	Rated Voltage ¹ FLA @ 208		Rated Voltage ¹ FLA @ 230		Rated Voltage ¹ FLA @ 460		Rated Voltage ¹ FLA @ 575	
	MCA ²	MOP ³	MCA ²	MOP ³	MCA ²	MOP ³	MCA ²	MOP ³
TCFW375	N/A	N/A	N/A	N/A	229	400	184	300

¹Allowable voltage is ± 10% from rated voltage.

²MCA is Minimum Circuit Amps, used for minimum wire size requirement.

³MOP is Maximum Overcurrent Protection, used for sizing main power protection device.



Thermal Care is ISO 9001 Certified
 Manufacturer reserves the right to change specification
 or design without notification or obligation.

