

# Accuchiller TSE Series

## Packaged Outdoor Chiller with Integral Tank

### Benefits:

- **Refrigerant Options:** EPA approved low GWP R-454B refrigerant or energy efficient R-410A refrigerant.
- **Direct-Drive Scroll Compressors:** Hermetically sealed scroll compressors with proven performance in industrial cooling for reliable, low maintenance, and efficient operation.
- **Stainless Steel Evaporators:** High efficiency stainless steel plates with copper brazing provide maximum performance, long life, and an enhanced level of protection from harsh process conditions.
- **Integral Tank:** Integrates a chiller with a complete process pumping system and integral reservoir in one package. Provides buffer for temperature stabilization all piped, insulated and wired to the chiller control panel for a quick and easy complete chilled water system installation (chiller and tank section ship separately).
- **Evaporator Inlet Strainer:** Removes any debris present in the process fluid to prevent costly downtime and repair due to a clogged chiller evaporator.
- **Fits through Doors:** Single circuit chillers up to 80 tons (281 kW) are compact and easily fit through standard 36-inch (914 mm) wide doors for easy maneuvering into tight installation spaces.
- **Dual Circuit Manifolds:** Dual circuit chillers include evaporator manifolds and water cooled condenser units include condenser water manifolds for quick and easy installation.
- **Warranty:** 1 year parts and labor.



The compact size of the Accuchiller TSE industrial central chiller minimizes floor space while delivering exceptional cooling capacity. Its modular design allows up to 12 refrigeration circuits to be combined into a single system for over 1,000 tons (3,517 kW) of cooling capacity. The chiller's innovative high flow design assures consistent process leaving water temperatures from 20°F to 80°F (-7°C to 27°C) and as low as 5°F (3°C) differential across the process.

Accuchiller TSE Series central chiller with tank integrates a chiller with a complete process pumping system and reservoir in one package to minimize floor space. Units come fully assembled and wired, ready for quick and simple installation and include an insulated integral tank and pumping system mounted on the

same frame. With a process pump and chiller pump as standard or with an optional dual standby or dedicated standby pumps, this package provides a wide range of options and configurations to suit any process need. All pumps are prewired to the control panel to save on costly field installation. All interconnecting piping, pumps, manifolds, and reservoir are insulated to prevent condensation and improve the system efficiency.

TSE Series chillers feature Dynamic Lift Technology, which continuously calculates optimal refrigerant pressure based on operating conditions. This innovation maximizes chiller energy savings and ensures stable, smooth control of refrigerant pressure, especially under fluctuating loads and condenser inlet temperatures.

## Benefits of the TSE Series Industrial Chiller with Integral Tank Features:

### INTEGRAL TANK

An integral reservoir, with pumping system make this TSE a self-contained, complete chilled water system.

### DIRECT-DRIVE SCROLL COMPRESSORS

Hermetically sealed scroll compressors are highly efficient and reliable. Low maintenance and industrial cooling - guaranteed.



### COMPACT FOOTPRINT

Designed to fit through standard 36-inch man doors, the single circuit chillers take up little space, and are easy to maneuver.

### MODULAR EXPANDABLE SYSTEM

Easily expand a system to over 1,000 tons, using up to six chillers and 12 refrigeration circuits.

### Additional Benefits:

- **Modular Expandable System:** System design provides for system expansion to over 1,000 tons (3,517 kW) using up to six chillers and twelve refrigeration circuits.
- **UL 508A Industrial Control Panel:** Meets rigorous standards for safe, reliable operation.
- **Single or Multiple Circuit Configurations:** Dual-circuit chillers for redundancy and back up of critical processes or systems and single-circuit chillers for dedicated loads.
- **7-inch Color Touch-Screen Display:** Controls, monitors and maintains stable and reliable chiller operation.
- **CONNEX4.0 Ready Controls:** Every chiller is equipped with an Ethernet port and is fully compatible with the CONNEX4.0 plant-wide equipment control and monitoring system.

### Available Options:

- **Rotary Non-Fused Disconnect Switch:** Adds a 5 kA SCCR (Short Circuit Current Rating) rotary non-fused disconnect switch to the control panel for safe lockout of main power.
- **12-inch HMI:** Replaces the standard 7-inch screen with a 12-inch, high resolution, color screen with a built-in industrial computer to allow for remote monitoring and control using Teamviewer software installed on any remote Windows based PC or smart phone.
- **12-inch HMI and Controller:** Replaces the standard 7-inch screen with a 12-inch, high resolution, color screen with a built-in industrial computer to allow for remote monitoring and control using Teamviewer software installed on any remote Windows based PC or smart phone. This package also adds a second PLC to allow for connection of up to 15 total Thermal Care CONNEX4.0 ready devices for many ways to interact with the connected equipment such as smart phone/tablet control, configurable email and text alerts for alarms, warnings, event alerts, and data collection.
- **BACnet Communications Port:** Adds a ModBUS to BACnet gateway which is wired to a RS-485 connector on the chiller control panel.

### 7-Inch Color Touch Screen

TSE SERIES		THERMAL CARE PiovonGroup		HOME
SYSTEM RUNNING				
PROCESS SETPOINT	50.0 °F	CKT1 DEMAND	0	
PROCESS SUPPLY	59.7 °F	STATUS	IDLE	
PROCESS RETURN	59.7 °F	IDLE	0 %	
PROCESS DELTA T	0.0 °F	COMP(S) ON	0	
CONDENSER IN	85.0 °F	CAPACITY	0.0 TON	
CONDENSER OUT	85.0 °F			

Home Screen

### CONNEX4.0

CONNEX 4.0		THERMAL CARE PiovonGroup		TSE
SYSTEM RUNNING - MONITORING SYSTEM DEMAND				
SETPOINT	50.0	CIRCUIT 1 COMP(S) ON	2	
CONDENSER FLUID IN	80 °F	COND OUT	95 °F	
EVAPORATOR FLUID IN	60.0 °F	EVAP OUT	50 °F	
TO PROCESS FLUID	50.0 °F	CAPACITY (TON)	80.0	
PROCESS DELTA T	10.0 °F			
STAGE DEMAND	100 %			

Diagnostics Screen

**TSEW10S - TSEW80S**

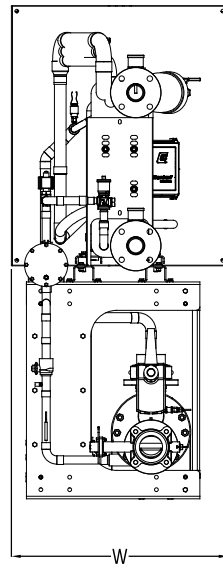
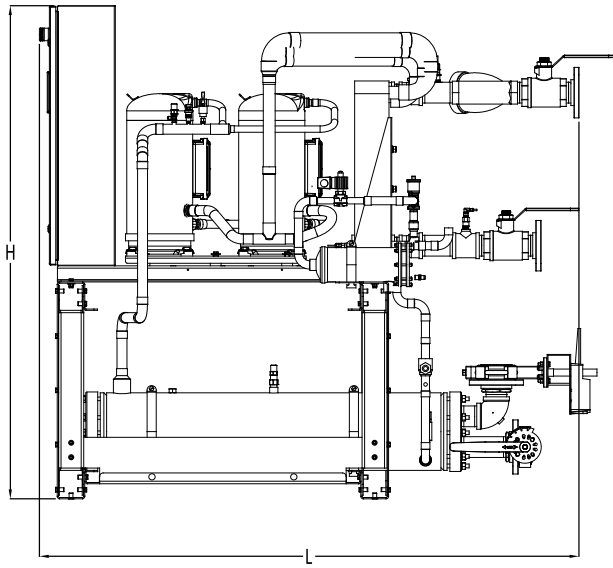

**TSEW20D - TSEW160D**

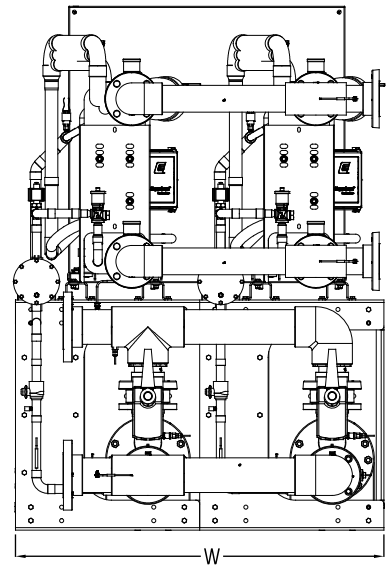
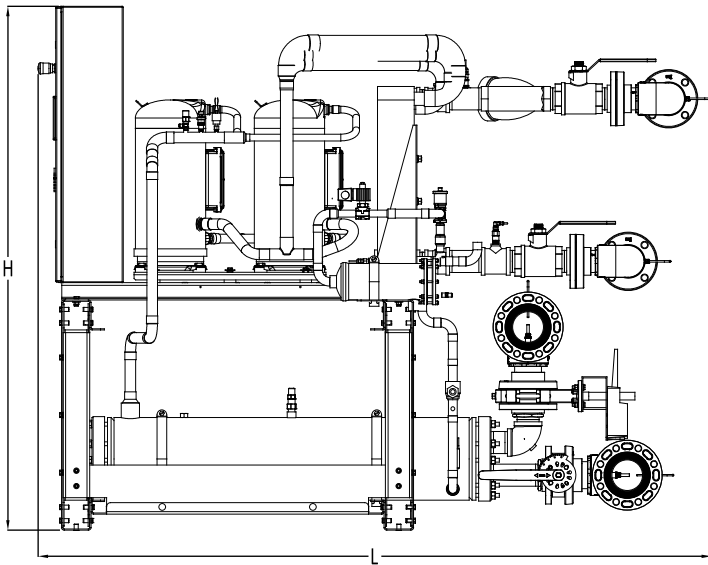

**TSER10S - TSER80S**

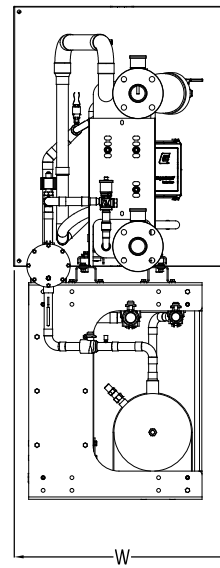
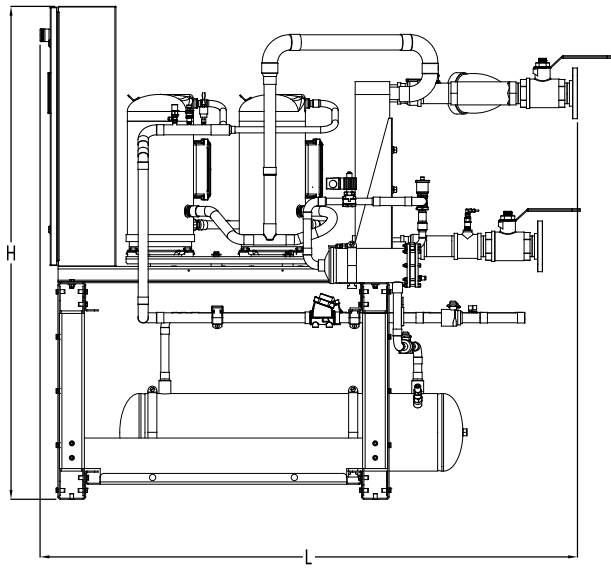

**TSER20D - TSER160D**

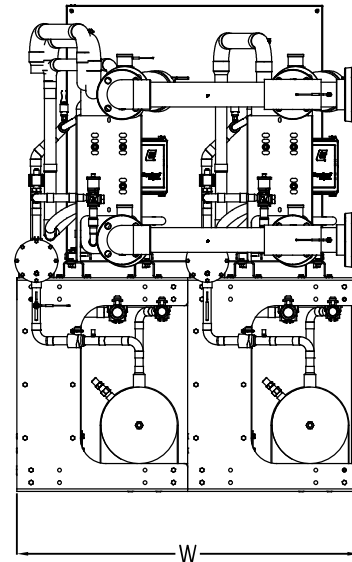
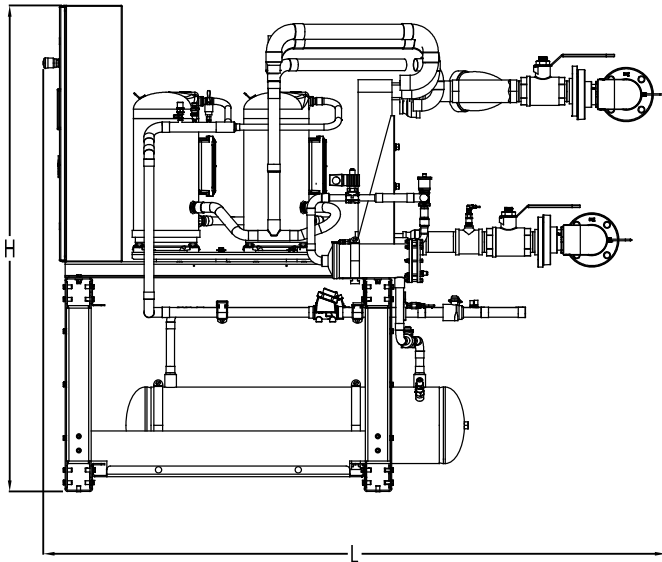

## Technical Data

Water Cooled Condenser Single Circuit Chillers	TSEW010S	TSEW015S	TSEW020S	TSEW025S	TSEW030S
<b>Cooling Capacity<sup>1</sup></b>	11 tons 39 kW	16 tons 56 kW	22 tons 77 kW	27 tons 95 kW	32 tons 113 kW
<b>Set Point Range</b>	20 to 80°F -7 to 27°C	20 to 80°F -7 to 27°C	20 to 80°F -7 to 27°C	20 to 80°F -7 to 27°C	20 to 80°F -7 to 27°C
<b>Compressor (qty)</b>	2	2	2	2	2
<b>Process In/Out (in) – Standard</b>	1½	1½	2	2	2½
<b>Process In/Out(in) – High Flow Option</b>	2	2½	2½	3	3
<b>Condenser Water In/Out (in)</b>	1½	2	2	2½	2½
<b>Chiller</b>					
<b>Dimensions L x W x H inch (mm)</b>	68 x 30 x 68 (1,727 x 762 x 1,727)	72 x 30 x 68 (1,829 x 762 x 1,727)	75 x 30 x 68 (1,905 x 762 x 1,727)	75 x 30 x 68 (1,905 x 762 x 1,727)	77 x 30 x 68 (1,956 x 762 x 1,727)
<b>Shipping Weight</b>	990 lbs 449 kg	1,072 lbs 486 kg	1,149 lbs 521 kg	1,189 lbs 539 kg	1,339 lbs 607 kg
<b>Operating Weight</b>	1,005 lbs 456 kg	1,092 lbs 495 kg	1,179 lbs 535 kg	1,222 lbs 554 kg	1,376 lbs 624 kg
<b>Chiller with Standard Flow Reservoir Option</b>					
<b>Reservoir Capacity</b>	275 gal 1,041 L	275 gal 1,041 L	275 gal 1,041 L	275 gal 1,041 L	275 gal 1,041 L
<b>Process/Chiller Pump</b>	5/1.5 hp 3.7/1.1 kW	5/1.5 hp 3.7/1.1 kW	5/1.5 hp 3.7/1.1 kW	5/1.5 hp 3.7/1.1 kW	7.5/2 hp 5.6/1.5 kW
<b>Process Connection Size (in)</b>	1½	1½	2	2	2½
<b>Condenser Water In/Out (in)</b>	1½	2	2	2½	2½
<b>Dimensions L x W x H inch (mm)</b>	99 x 68 x 73 (2,515 x 1,727 x 1,854)	99 x 72 x 73 (2,515 x 1,829 x 1,854)	99 x 75 x 73 (2,515 x 1,905 x 1,854)	99 x 75 x 73 (2,515 x 1,905 x 1,854)	99 x 78 x 73 (2,515 x 1,981 x 1,854)
<b>Shipping Weight</b>	2,337 lbs 1,061 kg	2,418 lbs 1,097 kg	2,496 lbs 1,132 kg	2,537 lbs 1,151 kg	2,769 lbs 1,256 kg
<b>Operating Weight</b>	4,631 lbs 2,101 kg	4,712 lbs 2,137 kg	4,790 lbs 2,173 kg	4,831 lbs 2,191 kg	5,063 lbs 2,297 kg
<b>Chiller with High Flow Reservoir Option</b>					
<b>Upsized Reservoir Capacity</b>	400 gal 1,514 L	400 gal 1,514 L	400 gal 1,514 L	400 gal 1,514 L	400 gal 1,514 L
<b>High Flow Process/Chiller Pump</b>	5/1.5 hp 3.7/1.1 kW	7.5/1.5 hp 5.6/1 kW	10/1.5 hp 7.5/1 kW	10/1.5 hp 7.5/1 kW	10/2 hp 7.5/1.5 kW
<b>Process Connection Size (in)</b>	2	2½	2½	3	3
<b>Condenser Water In/Out (in)</b>	1½	2	2	2½	2½
<b>Dimensions L x W x H inch (mm)</b>	99 x 68 x 73 (2,515 x 1,727 x 1,854)	99 x 72 x 73 (2,515 x 1,829 x 1,854)	99 x 75 x 73 (2,515 x 1,905 x 1,854)	99 x 75 x 73 (2,515 x 1,905 x 1,854)	99 x 78 x 73 (2,515 x 1,981 x 1,854)
<b>Shipping Weight</b>	2,850 lbs 1,293 kg	2,950 lbs 1,338 kg	3,100 lbs 1,406 kg	3,150 lbs 1,429 kg	3,450 lbs 1,565 kg
<b>Operating Weight</b>	6,200 lbs 2,812 kg	6,300 lbs 2,858 kg	6,450 lbs 2,926 kg	6,500 lbs 2,948 kg	6,800 lbs 3,084 kg

Water Cooled Condenser Single Circuit Chillers (additional models)	TSEW040S	TSEW050S	TSEW060S	TSEW080S
Cooling Capacity <sup>1</sup>	42 tons 148 kW	53 tons 186 kW	69 tons 243 kW	86 tons 302 kW
Set Point Range	20 to 80°F -7 to 27°C	20 to 80°F -7 to 27°C	20 to 80°F -7 to 27°C	20 to 80°F -7 to 27°C
Compressor (qty)	2	2	2	2
Process In/Out (in) – Standard	2½	3	4	4
Process In/Out(in) – High Flow Option	4	4	4	N/A
Condenser Water In/Out (in)	3	3	4	4
Chiller				
Dimensions L x W x H inch (mm)	102 x 30 x 68 (2,591 x 762 x 1,727)	92 x 36 x 68 (2,337 x 914 x 1,727)	102 x 36 x 68 (2,591 x 914 x 1,727)	102 x 36 x 68 (2,591 x 914 x 1,727)
Shipping Weight	1,763 lbs 800 kg	1,802 lbs 817 kg	2,294 lbs 1,041 kg	2,467 lbs 1,119 kg
Operating Weight	1,823 lbs 827 kg	1,872 lbs 849 kg	2,380 lbs 1,080 kg	2,557 lbs 1,160 kg
Chiller with Standard Flow Reservoir Option				
Reservoir Capacity	275 gal 1,041 L	275 gal 1,041 L	450 gal 1,703 L	450 gal 1,703 L
Process/Chiller Pump	10/2 hp 7.5/1.5 kW	10/3 hp 7.5/2.2 kW	10/3 hp 7.5/2.2 kW	15/3 hp 11.2/2.2 kW
Process Connection Size (in)	2½	3	3	4
Condenser Water In/Out (in)	3	3	4	4
Dimensions L x W x H inch (mm)	99 x 98 x 73 (2,515 x 2,489 x 1,854)	102 x 102 x 73 (2,591 x 2,591 x 1,854)	114 x 101 x 73 (2,896 x 2,565 x 1,854)	114 x 101 x 73 (2,896 x 2,565 x 1,854)
Shipping Weight	3,238 lbs 1,469 kg	3,374 lbs 1,530 kg	4,147 lbs 1,881 kg	4,370 lbs 1,982 kg
Operating Weight	5,532 lbs 2,509 kg	5,668 lbs 2,571 kg	7,901 lbs 3,584 kg	8,124 lbs 3,685 kg
Chiller with High Flow Reservoir Option				
Upsized Reservoir Capacity	400 gal 1,514 L	400 gal 1,514 L	650 gal 2,461 L	650 gal 2,461 L
High Flow Process/Chiller Pump	15/2 hp 11.2/1.5 kW	15/3 hp 11.2/2.2 kW	20/3 hp 15/2.2 kW	25/3 hp 18.6/2.2 kW
Process Connection Size (in)	4	4	4	6
Condenser Water In/Out (in)	3	3	4	4
Dimensions L x W x H inch (mm)	99 x 98 x 73 (2,515 x 2,489 x 1,854)	102 x 102 x 73 (2,591 x 2,591 x 1,854)	114 x 101 x 73 (2,896 x 2,565 x 1,854)	114 x 101 x 73 (2,896 x 2,565 x 1,854)
Shipping Weight	4,000 lbs 1,815 kg	4,250 lbs 1,928 kg	4,950 lbs 2,245 kg	5,750 lbs 2,608 kg
Operating Weight	7,350 lbs 3,334 kg	7,600 lbs 3,447 kg	10,400 lbs 4,717 kg	11,200 lbs 5,080 kg

Water Cooled Condenser Dual Circuit Chillers	TSEW020D	TSEW030D	TSEW040D	TSEW050D	TSEW060D
Cooling Capacity <sup>1</sup>	22 tons 77 kW	32 tons 113 kW	44 tons 155 kW	54 tons 190 kW	65 tons 229 kW
Set Point Range	20 to 80°F -7 to 27°C	20 to 80°F -7 to 27°C	20 to 80°F -7 to 27°C	20 to 80°F -7 to 27°C	20 to 80°F -7 to 27°C
Compressors Circuit 1 (qty)	2	2	2	2	2
Compressors Circuit 2 (qty)	2	2	2	2	2
Process In/Out (in) – Standard	2	2½	2½	3	3
Process In/Out(in) – High Flow Option	2½	3	4	4	4
Condenser Water In/Out (in)	2	2½	3	3	4
<b>Chiller</b>					
Dimensions L x W x H inch (mm)	76 x 48 x 68 (1,930 x 1,219 x 1,727)	77 x 49 x 68 (1,956 x 1,245 x 1,727)	80 x 50 x 68 (2,032 x 1,270 x 1,727)	81 x 50 x 68 (2,057 x 1,270 x 1,727)	87 x 52 x 68 (2,210 x 1,321 x 1,727)
Shipping Weight	1,925 lbs 873 kg	2,093 lbs 949 kg	2,255 lbs 1,023 kg	2,343 lbs 1,063 kg	2,657 lbs 1,205 kg
Operating Weight	1,955 lbs 887 kg	2,133 lbs 968 kg	2,315 lbs 1,050 kg	2,409 lbs 1,093 kg	2,731 lbs 1,239 kg
<b>Chiller with Standard Flow Reservoir Option</b>					
Reservoir Capacity	275 gal 1,041 L	275 gal 1,041 L	275 gal 1,041 L	275 gal 1,041 L	450 gal 1,703 L
Process/Chiller Pump	5/1.5 hp 3.7/1.1 kW	7.5/2 hp 5.6/1.5 kW	10/2 hp 7.5/1.5 kW	10/3 hp 7.5/2.2 kW	10/3 hp 7.5/2.2 kW
Process Connection Size (in)	2	2½	2½	3	3
Condenser Water In/Out (in)	2	2½	3	3	4
Dimensions L x W x H inch (mm)	123 x 74 x 73 (3,124 x 1,880 x 1,854)	123 x 74 x 73 (3,124 x 1,880 x 1,854)	123 x 77 x 73 (3,124 x 1,956 x 1,854)	123 x 78 x 75 (3,124 x 1,981 x 1,905)	135 x 81 x 75 (3,429 x 2,057 x 1,905)
Shipping Weight	3,486 lbs 1,581 kg	3,748 lbs 1,700 kg	3,948 lbs 1,791 kg	4,068 lbs 1,845 kg	4,546 lbs 2,062 kg
Operating Weight	5,780 lbs 2,622 kg	6,042 lbs 2,741 kg	6,229 lbs 2,825 kg	6,362 lbs 2,886 kg	8,300 lbs 3,765 kg
<b>Chiller with High Flow Reservoir Option</b>					
Upsized Reservoir Capacity	400 gal 1,514 L	400 gal 1,514 L	400 gal 1,514 L	400 gal 1,514 L	650 gal 2,461 L
High Flow Process/Chiller Pump	10/1.5 hp 7.5/1.1 kW	10/2 hp 7.5/1.5 kW	15/2 hp 11.2/1.5 kW	15/3 hp 11.2/2.2 kW	20/3 hp 15/2.2 kW
Process Connection Size (in)	2½	3	4	4	4
Condenser Water In/Out (in)	2	2½	3	3	4
Dimensions L x W x H inch (mm)	123 x 74 x 73 (3,124 x 1,880 x 1,854)	123 x 74 x 73 (3,124 x 1,880 x 1,854)	123 x 77 x 73 (3,124 x 1,956 x 1,854)	123 x 78 x 75 (3,124 x 1,981 x 1,905)	135 x 81 x 75 (3,429 x 2,057 x 1,905)
Shipping Weight	5,950 lbs 2,699 kg	6,400 lbs 2,903 kg	6,750 lbs 3,062 kg	6,950 lbs 3,153 kg	8,950 lbs 4,060 kg
Operating Weight	7,200 lbs 3,266 kg	7,650 lbs 3,470 kg	8,000 lbs 3,629 kg	8,200 lbs 3,720 kg	10,900 lbs 4,944 kg

Water Cooled Condenser Dual Circuit Chillers (additional models)	TSEW080D	TSEW100D	TSEW120D	TSEW160D
<b>Cooling Capacity<sup>1</sup></b>	84 tons 295 kW	106 tons 373 kW	137 tons 482 kW	171 tons 601 kW
<b>Set Point Range</b>	20 to 80°F -7 to 27°C	20 to 80°F -7 to 27°C	20 to 80°F -7 to 27°C	20 to 80°F -7 to 27°C
<b>Compressors Circuit 1 (qty)</b>	2	2	2	2
<b>Compressors Circuit 2 (qty)</b>	2	2	2	2
<b>Process In/Out (in) – Standard</b>	4	4	4	6
<b>Process In/Out(in) – High Flow Option</b>	6	6	6	N/A
<b>Condenser Water In/Out (in)</b>	4	4	6	6
<b>Chiller</b>				
<b>Dimensions L x W x H inch (mm)</b>	117 x 51 x 68 (2,972 x 1,295 x 1,727)	113 x 52 x 68 (2,870 x 1,321 x 1,727)	119 x 54 x 68 (3,023 x 1,372 x 1,727)	120 x 54 x 68 (3,048 x 1,372 x 1,727)
<b>Shipping Weight</b>	3,516 lbs 1,595 kg	3,595 lbs 1,631 kg	4,361 lbs 1,978 kg	4,736 lbs 2,148 kg
<b>Operating Weight</b>	3,636 lbs 1,649 kg	3,735 lbs 1,694 kg	4,533 lbs 2,056 kg	4,916 lbs 2,230 kg
<b>Chiller with Standard Flow Reservoir Option</b>				
<b>Reservoir Capacity</b>	450 gal 1,703 L	700 gal 2,650 L	700 gal 2,650 L	1,000 gal 3,785 L
<b>Process/Chiller Pump</b>	15/3 hp 11.2/2.2 kW	15/5 hp 11.2/3.7 kW	20/7.5 hp 14.9/3.7 kW	25/10 hp 18.6/7.5 kW
<b>Process Connection Size (in)</b>	4	4	4	6
<b>Condenser Water In/Out (in)</b>	4	4	6	6
<b>Dimensions L x W x H inch (mm)</b>	135 x 98 x 79 (3,429 x 2,489 x 2,007)	135 x 102 x 79 (3,429 x 2,591 x 2,007)	135 x 111 <sup>2</sup> x 79 (3,429 x 2,819 x 2,007)	148 x 111 <sup>2</sup> x 90 (3,759 x 2,819 x 2,286)
<b>Shipping Weight</b>	5,390 lbs 2,445 kg	6,067 lbs 2,752 kg	7,160 lbs 3,248 kg	8,168 lbs 3,705 kg
<b>Operating Weight</b>	9,144 kg 4,148 kg	11,936 lbs 5,414 kg	12,999 lbs 5,896 kg	16,510 lbs 7,489 kg
<b>Chiller with High Flow Reservoir Option</b>				
<b>Upsized Reservoir Capacity</b>	650 gal 2,461 L	1,000 gal 3,785 L	1,000 gal 3,785 L	1,000 gal 3,785 L
<b>High Flow Process/Chiller Pump</b>	25/3 hp 18.6/2.2 kW	30/5 hp 22.4/3.7 kW	40/7.5 hp 29.8/5.6 kW	40/10 hp 29.8/7.5 kW
<b>Process Connection Size (in)</b>	6	6	6	6
<b>Condenser Water In/Out (in)</b>	4	4	6	6
<b>Dimensions L x W x H inch (mm)</b>	135 x 98 x 79 (3,429 x 2,489 x 2,007)	135 x 102 x 79 (3,429 x 2,591 x 2,007)	135 x 111 x 79 (3,429 x 2,819 x 2,007)	148 x 111 x 90 (3,759 x 2,819 x 2,286)
<b>Shipping Weight</b>	10,300 lbs 4,672 kg	13,050 lbs 5,919 kg	14,150 lbs 6,418 kg	18,500 lbs 8,392 kg
<b>Operating Weight</b>	12,250 lbs 5,557 kg	16,250 lbs 7,371 kg	17,250 lbs 7,825 kg	19,500 lbs 8,845 kg

Remote Air Cooled Condenser Single Circuit Chillers	TSER010S	TSER015S	TSER020S	TSER025S	TSER030S
Cooling Capacity <sup>1</sup>	10 tons 35 kW	15 tons 53 kW	20 tons 70 kW	25 tons 88 kW	30 tons 105 kW
Set Point Range	20 to 80°F -7 to 27°C	20 to 80°F -7 to 27°C	20 to 80°F -7 to 27°C	20 to 80°F -7 to 27°C	20 to 80°F -7 to 27°C
Compressor (qty)	2	2	2	2	2
Process In/Out(in) – Standard	1½	1½	2	2	2½
Process In/Out(in) – High Flow Option	2	2½	2½	3	3
Refrigerant Discharge Line (in)	¾	1⅝	1⅝	1¾	1¾
Refrigerant Liquid Line (in)	¾	¾	¾	1⅝	1⅝
<b>Chiller</b>					
Dimensions L x W x H inch (mm)	64 x 30 x 68 (1,626 x 762 x 1,727)	65 x 30 x 68 (1,651 x 762 x 1,727)	68 x 30 x 68 (1,727 x 762 x 1,727)	68 x 30 x 68 (1,727 x 762 x 1,727)	74 x 30 x 68 (1,880 x 762 x 1,727)
Shipping Weight	897 lbs 407 kg	1,024 lbs 465 kg	1,060 lbs 481 kg	1,076 lbs 488 kg	1,202 lbs 545 kg
Operating Weight	912 lbs 414 kg	1,044 lbs 474 kg	1,090 lbs 494 kg	1,109 lbs 503 kg	1,239 lbs 562 kg
<b>Chiller with Standard Flow Reservoir Option</b>					
Reservoir Capacity	275 gal 1,041 L	275 gal 1,041 L	275 gal 1,041 L	275 gal 1,041 L	275 gal 1,041 L
Process/Chiller Pump	5/1.5 hp 3.7/1.1 kW	5/1.5 hp 3.7/1.1 kW	5/1.5 hp 3.7/1.1 kW	5/1.5 hp 3.7/1.1 kW	7.5/2 hp 5.6/1.5 kW
Process Connection Size (in)	1½	1½	2	2	2½
Refrigerant Discharge Line (in)	¾	1⅝	1⅝	1¾	1¾
Refrigerant Liquid Line (in)	¾	¾	¾	1⅝	1⅝
Dimensions L x W x H inch (mm)	99 x 66 x 73 (2,515 x 1,676 x 1,854)	99 x 66 x 73 (2,515 x 1,676 x 1,854)	99 x 67 x 73 (2,515 x 1,702 x 1,854)	99 x 67 x 73 (2,515 x 1,702 x 1,854)	99 x 71 x 73 (2,515 x 1,803 x 1,854)
Shipping Weight	2,267 lbs 1,028 kg	2,370 lbs 1,075 kg	2,407 lbs 1,092 kg	2,423 lbs 1,099 kg	2,628 lbs 1,192 kg
Operating Weight	4,561 lbs 2,069 kg	4,664 lbs 2,116 kg	4,701 lbs 2,132 kg	4,717 lbs 2,140 kg	4,922 lbs 2,233 kg
<b>Chiller with High Flow Reservoir Option</b>					
Upsized Reservoir Capacity	400 gal 1,514 L	400 gal 1,514 L	400 gal 1,514 L	400 gal 1,514 L	400 gal 1,514 L
High Flow Process/Chiller Pump	5/1.5 hp 3.7/1.1 kW	7.5/1.5 hp 5.6/1.5 kW	10/1.5 hp 7.5/1.1 kW	10/1.5 hp 7.5/1.1 kW	10/2 hp 7.5/1.5 kW
Process Connection Size (in)	2	2½	2½	3	3
Refrigerant Discharge Line (in)	¾	1⅝	1⅝	1¾	1¾
Refrigerant Liquid Line (in)	¾	¾	¾	1⅝	1⅝
Dimensions L x W x H inch (mm)	99 x 66 x 73 (2,515 x 1,676 x 1,854)	99 x 66 x 73 (2,515 x 1,676 x 1,854)	99 x 67 x 73 (2,515 x 1,702 x 1,854)	99 x 67 x 73 (2,515 x 1,702 x 1,854)	99 x 71 x 73 (2,515 x 1,803 x 1,854)

Remote Air Cooled Condenser Single Circuit Chillers (additional models)	TSER040S	TSER050S	TSER060S	TSER080S
Cooling Capacity <sup>1</sup>	39 tons 137 kW	49 tons 172 kW	64 tons 225 kW	79 tons 278 kW
Set Point Range	20 to 80°F -7 to 27°C	20 to 80°F -7 to 27°C	20 to 80°F -7 to 27°C	20 to 80°F -7 to 27°C
Compressor (qty)	2	2	2	2
Process In/Out(in) – Standard	2½	3	4	4
Process In/Out(in) – High Flow Option	4	4	4	N/A
Refrigerant Discharge Line (in)	1¾	1¾	1¾	2¾
Refrigerant Liquid Line (in)	1¾	1¾	1¾	1¾
<b>Chiller</b>				
Dimensions L x W x H inch (mm)	102 x 30 x 68 (2,591 x 762 x 1,727)	99 x 36 x 68 (2,515 x 914 x 1,727)	102 x 36 x 68 (2,591 x 914 x 1,727)	102 x 36 x 68 (2,591 x 914 x 1,727)
Shipping Weight	1,554 lbs 705 kg	1,588 lbs 720 kg	1,995 lbs 905 kg	2,161 lbs 980 kg
Operating Weight	1,614 lbs 732 kg	1,658 lbs 752 kg	2,081 lbs 944 kg	2,251 lbs 1021 kg
<b>Chiller with Standard Flow Reservoir Option</b>				
Reservoir Capacity	275 gal 1,041 L	275 gal 1,041 L	450 gal 1,703 L	450 gal 1,703 L
Process/Chiller Pump	10/2 hp 7.5/1.5 kW	10/3 hp 7.5/2.2 kW	10/3 hp 7.5/2.2 kW	15/3 hp 11.2/2.2 kW
Process Connection Size (in)	2½	3	3	4
Refrigerant Discharge Line (in)	1¾	1¾	1¾	2¾
Refrigerant Liquid Line (in)	1¾	1¾	1¾	1¾
Dimensions L x W x H inch (mm)	99 x 98 x 73 (2,515 x 2,489 x 1,854)	102 x 102 x 73 (2,591 x 2,591 x 1,854)	114 x 101 x 73 (2,896 x 2,565 x 1,854)	114 x 101 x 73 (2,896 x 2,565 x 1,854)
Shipping Weight	3,030 lbs 1,374 kg	3,158 lbs 1,432 kg	3,846 lbs 1,745 kg	4,063 lbs 1,843 kg
Operating Weight	5,324 lbs 2,415 kg	5,452 lbs 2,473 kg	7,600 lbs 3,447 kg	7,817 lbs 3,546 kg
<b>Chiller with High Flow Reservoir Option</b>				
Upsized Reservoir Capacity	400 gal 1,514 L	400 gal 1,514 L	650 gal 2,461 L	650 gal 2,461 L
High Flow Process/Chiller Pump	15/2 hp 11.2/1.5 kW	15/3 hp 11.2/2.2 kW	20/3 hp 14.9/2.2 kW	25/3 hp 18.6/2.2 kW
Process Connection Size (in)	4	4	4	6
Refrigerant Discharge Line (in)	1¾	1¾	1¾	2¾
Refrigerant Liquid Line (in)	1¾	1¾	1¾	1¾
Dimensions L x W x H inch (mm)	99 x 98 x 73 (2,515 x 2,489 x 1,854)	102 x 102 x 73 (2,591 x 2,591 x 1,854)	114 x 101 x 73 (2,896 x 2,565 x 1,854)	114 x 101 x 73 (2,896 x 2,565 x 1,854)
Shipping Weight	3,750 lbs 1,701 kg	4,000 lbs 1,814 kg	4,600 lbs 2,087 kg	5,350 lbs 2,427 kg
Operating Weight	7,100 lbs 3,221 kg	7,350 lbs 3,334 kg	10,050 lbs 4,559 kg	10,800 lbs 4,899 kg

Remote Air Cooled Condenser Dual Circuit Chillers	TSER020D	TSER030D	TSER040D	TSER050D	TSER060D
<b>Cooling Capacity<sup>1</sup></b>	20 tons 70 kW	30 tons 105 kW	41 tons 144 kW	50 tons 176 kW	60 tons 211 kW
<b>Set Point Range</b>	20 to 80°F -7 to 27°C	20 to 80°F -7 to 27°C	20 to 80°F -7 to 27°C	20 to 80°F -7 to 27°C	20 to 80°F -7 to 27°C
<b>Compressors Circuit 1 (qty)</b>	2	2	2	2	2
<b>Compressors Circuit 2 (qty)</b>	2	2	2	2	2
<b>Process In/Out(in) – Standard</b>	2	2½	2½	3	3
<b>Process In/Out(in) – High Flow Option</b>	2½	3	4	4	4
<b>Refrigerant Discharge Line (in)</b>	¾	1⅛	1⅛	1⅜	1⅜
<b>Refrigerant Liquid Line (in)</b>	¾	¾	¾	1⅛	1⅛
<b>Chiller</b>					
<b>Dimensions L x W x H inch (mm)</b>	76 x 48 x 68 (1,930 x 1,219 x 1,727)	77 x 48 x 68 (1,956 x 1,219 x 1,727)	80 x 48 x 68 (2,032 x 1,219 x 1,727)	81 x 48 x 68 (2,057 x 1,219 x 1,727)	87 x 48 x 68 (2,210 x 1,219 x 1,727)
<b>Shipping Weight</b>	1,722 lbs 781 kg	1,760 lbs 798 kg	1,834 lbs 832 kg	2,091 lbs 949 kg	2,335 lbs 1,059 kg
<b>Operating Weight</b>	1,752 lbs 795 kg	1,800 lbs 817 kg	1,894 lbs 859 kg	2,157 lbs 978 kg	2,409 lbs 1,093 kg
<b>Chiller with Standard Flow Reservoir Option</b>					
<b>Reservoir Capacity</b>	275 gal 1,041 L	275 gal 1,041 L	275 gal 1,041 L	275 gal 1,041 L	450 gal 1,703 L
<b>Process/Chiller Pump</b>	5/1.5 hp 3.7/1.1 kW	7.5/2 hp 5.6/1.5 kW	10/2 hp 7.5/1.5 kW	10/3 hp 7.5/2.2 kW	10/3 hp 7.5/2.2 kW
<b>Process Connection Size (in)</b>	2	2½	2½	3	3
<b>Refrigerant Discharge Line (in)</b>	¾	1⅛	1⅛	1⅜	1⅜
<b>Refrigerant Liquid Line (in)</b>	¾	¾	¾	1⅛	1⅛
<b>Dimensions L x W x H inch (mm)</b>	123 x 66 x 72 (3,124 x 1,676 x 1,829)	123 x 66 x 72 (3,124 x 1,676 x 1,829)	123 x 67 x 72 (3,124 x 1,702 x 1,829)	123 x 68 x 75 (3,124 x 1,727 x 1,905)	135 x 71 x 75 (3,429 x 1,803 x 1,905)
<b>Shipping Weight</b>	3,335 lbs 1,513 kg	3,634 lbs 1,648 kg	3,624 lbs 1,644 kg	3,814 lbs 1,730 kg	4,224 lbs 1,916 kg
<b>Operating Weight</b>	5,629 lbs 2,553 kg	5,928 lbs 2,689 kg	5,918 lbs 2,684 kg	6,109 lbs 2,771 kg	7,978 lbs 3,619 kg
<b>Chiller with High Flow Reservoir Option</b>					
<b>Upsized Reservoir Capacity</b>	400 gal 1,514 L	400 gal 1,514 L	400 gal 1,514 L	400 gal 1,514 L	650 gal 2,461 L
<b>High Flow Process/Chiller Pump</b>	10/1.5 hp 7.5/1.2 kW	10/1.5 hp 7.5/1.5 kW	15/2 hp 11.2/1.5 kW	15/3 hp 11.2/2.2 kW	20/3 hp 14.9/2.2 kW
<b>Process Connection Size (in)</b>	2½	3	4	4	4
<b>Refrigerant Discharge Line (in)</b>	¾	1⅛	1⅛	1⅜	1⅜
<b>Refrigerant Liquid Line (in)</b>	¾	¾	¾	1⅛	1⅛
<b>Dimensions L x W x H inch (mm)</b>	123 x 66 x 72 (3,124 x 1,676 x 1,829)	123 x 66 x 72 (3,124 x 1,676 x 1,829)	123 x 67 x 72 (3,124 x 1,702 x 1,829)	123 x 68 x 75 (3,124 x 1,727 x 1,905)	135 x 71 x 75 (3,429 x 1,803 x 1,905)
<b>Shipping Weight</b>	3,850 lbs 1,746 kg	4,200 lbs 1,905 kg	4,400 lbs 1,996 kg	4,550 lbs 2,064 kg	5,050 lbs 2,291 kg
<b>Operating Weight</b>	7,200 lbs 3,266 kg	7,550 lbs 3,425 kg	7,750 lbs 3,515 kg	7,900 lbs 3,583 kg	10,500 lbs 4,763 kg

Remote Air Cooled Condenser Dual Circuit Chillers (additional models)	TSER080D	TSER100D	TSER120D	TSER160D
Cooling Capacity <sup>1</sup>	78 tons 274 kW	98 tons 345 kW	127 tons 447 kW	158 tons 556 kW
Set Point Range	20 to 80°F -7 to 27°C	20 to 80°F -7 to 27°C	20 to 80°F -7 to 27°C	20 to 80°F -7 to 27°C
Compressors Circuit 1 (qty)	2	2	2	2
Compressors Circuit 2 (qty)	2	2	2	2
Process In/Out(in) – Standard	4	4	4	6
Process In/Out(in) – High Flow Option	6	6	6	N/A
Refrigerant Discharge Line (in)	1½	1½	1½	2½
Refrigerant Liquid Line (in)	1½	1½	1½	1½
<b>Chiller</b>				
Dimensions L x W x H inch (mm)	117 x 49 x 68 (2,972 x 1,245 x 1,727)	113 x 49 x 68 (2,870 x 1,245 x 1,727)	116 x 49 x 68 (2,946 x 1,245 x 1,727)	120 x 51 x 68 (3,048 x 1,295 x 1,727)
Shipping Weight	3,061 lbs 1,388 kg	3,129 lbs 1,419 kg	3,820 lbs 1,733 kg	4,069 lbs 1,846 kg
Operating Weight	3,181 lbs 1,443 kg	3,269 lbs 1,483 kg	3,992 lbs 1,811 kg	4,249 lbs 1,927 kg
<b>Chiller with Standard Flow Reservoir Option</b>				
Reservoir Capacity	450 gal 1,703 L	700 gal 2,650 L	700 gal 2,650 L	1,000 gal 3,785 L
Process/Chiller Pump	15/3 hp 11.2/2.2 kW	15/5 hp 11.2/3.7 kW	20/7.5 hp 14.9/5.6 kW	25/10 hp 18.6/7.5 kW
Process Connection Size (in)	4	4	4	6
Refrigerant Discharge Line (in)	1½	1½	1½	2½
Refrigerant Liquid Line (in)	1½	1½	1½	1½
Dimensions L x W x H inch (mm)	135 x 99 x 75 (3,429 x 2,515 x 1,905)	135 x 99 x 78 (3,429 x 2,515 x 1,981)	135 x 98 x 79 (3,429 x 2,489 x 2,006)	148 x 101 x 90 (3,759 x 2,565 x 2,286)
Shipping Weight	5,040 lbs 2,286 kg	5,628 lbs 2,553 kg	6,478 lbs 2,938 kg	7,499 lbs 3,402 kg
Operating Weight	8,794 lbs 3,989 kg	11,467 lbs 5,201 kg	12,317 lbs 5,587 kg	15,841 lbs 7,186 kg

Remote Air Cooled Condenser Dual Circuit Chillers (additional models continued)	TSER080D	TSER100D	TSER120D	TSER160D
<b>Chiller with High Flow Reservoir Option</b>				
<b>Upsized Reservoir Capacity</b>	650 gal 2,461 L	1,000 gal 3,785 L	1,000 gal 3,785 L	1,000 gal 3,785 L N/A
<b>High Flow Process/Chiller Pump</b>	25/3 hp 18.6/2.2 kW	30/5 hp 22.4/3.7 kW	40/7.5 hp 30/5.6 kW	40/10 hp 29.8/7.5 kW
<b>Process Connection Size (in)</b>	6	6	6	6
<b>Refrigerant Discharge Line (in)</b>	1 $\frac{3}{8}$	1 $\frac{3}{8}$	1 $\frac{3}{8}$	2 $\frac{1}{8}$
<b>Refrigerant Liquid Line (in)</b>	1 $\frac{3}{8}$	1 $\frac{3}{8}$	1 $\frac{3}{8}$	1 $\frac{3}{8}$
<b>Dimensions L x W x H inch (mm)</b>	135 x 99 x 75 (3,429 x 2,515 x 1,905)	135 x 99 x 78 (3,429 x 2,515 x 1,981)	135 x 98 x 78 (3,429 x 2,489 x 1,981)	148 x 101 x 90 (3,759 x 2,565 x 2,286)
<b>Shipping Weight</b>	6,250 lbs 2,835 kg	7,300 lbs 3,311 kg	8,100 lbs 3,674 kg	10,300 lbs 4,672 kg
<b>Operating Weight</b>	11,700 lbs 5,307 kg	15,650 lbs 7,099 kg	16,450 lbs 7,462 kg	18,650 lbs 8,460 kg

<sup>1</sup>Cooling capacity when cooling water with 50°F (10°C) set point, 60°F (16°C) return, 85°F (29°C) condenser water or 95°F (35°C) condenser air, R410A or R454B refrigerant.

<sup>2</sup>To keep shipping dimensions within the 102" (259cm) width of a standard flatbed, the condenser inlet manifold ships separately.

Remote Condensers Circuit Type	KCM014 Single Circuit	KCL023 Single Circuit	KCL030 Single Circuit	KCL037 Single Circuit	KCL045 Single Circuit	KCL056 Single Circuit
<b>Chiller Used With Number of Fans</b>	TSER010S 2	TSER015S 2	TSER020S 2	TSER025S 2	TSER030S 3	TSER040S 3
<b>Refrigerant Inlet (in)</b>	1 $\frac{3}{8}$	2 $\frac{1}{8}$	2 $\frac{1}{8}$	2 $\frac{1}{8}$	2 $\frac{5}{8}$	2 $\frac{5}{8}$
<b>Refrigerant Outlet (in)</b>	1 $\frac{3}{8}$	1 $\frac{3}{8}$	1 $\frac{5}{8}$	1 $\frac{5}{8}$	1 $\frac{5}{8}$	2 $\frac{1}{8}$
<b>Dimensions L x W x H inch (mm)</b>	83 x 43 x 48 (2,108 x 1,092 x 1,219)	113 x 45 x 54 (2,870 x 1,143 x 1,372)	113 x 45 x 54 (2,870 x 1,143 x 1,372)	113 x 45 x 54 (2,870 x 1,143 x 1,372)	168 x 45 x 54 (4,267 x 1,143 x 1,372)	168 x 45 x 54 (4,267 x 1,143 x 1,372)
<b>Shipping Weight</b>	415 lbs 188 kg	680 lbs 308 kg	720 lbs 327 kg	1,050 lbs 476 kg	1,075 lbs 488 kg	1,450 lbs 658 kg
<b>Operating Weight</b>	Varies based on system refrigerant charge and operating conditions					

Remote Condensers Circuit Type	KCL068 Single Circuit	KCL095 Single Circuit	KCL110 Single Circuit	KCM034 Dual Circuit	KCL047 Dual Circuit	KCL060 Dual Circuit
<b>Chiller Used With Number of Fans</b>	TSER050S 4	TSER060S 5	TSER080S 6	TSER020D 4	TSER030D 4	TSER040D 4
<b>Refrigerant Inlet (in)</b>	2 $\frac{1}{2}$	3 $\frac{1}{8}$	3 $\frac{1}{8}$	1 $\frac{1}{2}$	2 $\frac{1}{8}$	2 $\frac{1}{8}$
<b>Refrigerant Outlet (in)</b>	2 $\frac{1}{2}$	2 $\frac{1}{8}$	2 $\frac{1}{2}$	1 $\frac{1}{2}$	1 $\frac{3}{8}$	1 $\frac{1}{2}$
<b>Dimensions L x W x H inch (mm)</b>	223 x 45 x 54 (5,664 x 1,143 x 1,372)	278 x 45 x 54 (7,061 x 1,143 x 1,372)	333 x 45 x 54 (8,458 x 1,143 x 1,372)	87 x 83 x 48 (2,210 x 2,108 x 1,219)	113 x 87 x 54 (2,870 x 2,210 x 1,372)	113 x 87 x 54 (2,870 x 2,210 x 1,372)
<b>Shipping Weight</b>	1,475 lbs 669 kg	1,950 lbs 885 kg	2,300 lbs 1,043 kg	830 lbs 377 kg	1,175 lbs 533 kg	1,525 lbs 692 kg
<b>Operating Weight</b>	Varies based on system refrigerant charge and operating conditions					

Remote Condensers (continued) Circuit Type	KCL074 Dual Circuit	KCL090 Dual Circuit	KCL112 Dual Circuit	KCL137 Dual Circuit	KCL190 Dual Circuit	KCL224 Dual Circuit
Chiller Used With Number of Fans	TSER050D 4	TSER060D 6	TSER080D 6	TSER100D 8	TSER120D 10	TSER160D 12
Refrigerant Inlet (in) Refrigerant Outlet (in)	2 $\frac{1}{8}$ 1 $\frac{1}{8}$	2 $\frac{1}{8}$ 1 $\frac{3}{8}$	2 $\frac{5}{8}$ 2 $\frac{1}{2}$	2 $\frac{5}{8}$ 2 $\frac{1}{2}$	3 $\frac{1}{8}$ 2 $\frac{5}{8}$	3 $\frac{1}{8}$ 2 $\frac{5}{8}$
Dimensions L x W x H inch (mm)	113 x 87 x 54 (2,870 x 2,210 x 1,372)	168 x 87 x 54 (4,267 x 2,210 x 1,372)	168 x 87 x 54 (4,267 x 2,210 x 1,372)	223 x 87 x 54 (5,664 x 2,210 x 1,372)	278 x 87 x 54 (7,061 x 2,210 x 1,372)	333 x 87 x 54 (8,458 x 2,210 x 1,372)
Shipping Weight	1,525 lbs 692 kg	2,000 lbs 907 kg	2,275 lbs 1,032 kg	2,800 lbs 1,270 kg	3,700 lbs 1,678 kg	4,400 lbs 1,996 kg
Operating Weight	Varies based on system refrigerant charge and operating conditions					

## Electrical Data

Model	Chiller Only							
	Rated Voltage <sup>1</sup> FLA @ 208		Rated Voltage <sup>1</sup> FLA @ 230		Rated Voltage <sup>1</sup> FLA @ 460		Rated Voltage <sup>1</sup> FLA @ 575	
	MCA <sup>2</sup>	MOP <sup>3</sup>	MCA <sup>2</sup>	MOP <sup>3</sup>	MCA <sup>2</sup>	MOP <sup>3</sup>	MCA <sup>2</sup>	MOP <sup>3</sup>
TSEW10S & TSER10S	44	70	44	70	23	35	18	25
TSEW15S & TSER15S	71	110	71	110	37	60	30	45
TSEW20S & TSER20S	101	150	101	150	48	70	39	60
TSEW25S & TSER25S	112	175	112	175	57	90	48	170
TSEW30S & TSER30S	123	200	123	200	64	100	57	90
TSEW40S & TSER40S	170	250	170	250	82	125	64	100
TSEW50S & TSER50S	197	300	197	300	100	150	71	110
TSEW60S & TSER60S	249	400	249	400	129	200	91	150
TSEW80S & TSER80S	N/A	500	N/A	500	172	250	125	200
TSEW20D & TSER20D	83	110	83	110	42	60	33	40
TSEW30D & TSER30D	134	175	134	175	69	90	56	70
TSEW40D & TSER40D	189	250	189	250	90	125	73	90
TSEW50D & TSER50D	210	300	210	300	107	150	90	125
TSEW60D & TSER60D	231	300	231	300	120	150	107	150
TSEW80D & TSER80D	321	400	321	400	154	200	120	150
TSEW100D & TSER100D	372	500	372	500	188	250	133	175
TSEW120D & TSER120D	469	600	469	600	243	300	171	225
TSEW160D & TSER160D	N/A	N/A	N/A	N/A	324	400	235	300

Model	Chiller with Standard Flow Pumps							
	Rated Voltage <sup>1</sup> FLA @ 208		Rated Voltage <sup>1</sup> FLA @ 230		Rated Voltage <sup>1</sup> FLA @ 460		Rated Voltage <sup>1</sup> FLA @ 575	
	MCA <sup>2</sup>	MOP <sup>3</sup>	MCA <sup>2</sup>	MOP <sup>3</sup>	MCA <sup>2</sup>	MOP <sup>3</sup>	MCA <sup>2</sup>	MOP <sup>3</sup>
TSEW10S & TSER10S	67	90	65	90	33	45	26	35
TSEW15S & TSER15S	91	125	89	125	45	70	37	60
TSEW20S & TSER20S	117	175	115	175	55	80	45	70
TSEW25S & TSER25S	127	200	125	200	63	100	74	100
TSEW30S & TSER30S	147	225	144	225	74	110	65	100
TSEW40S & TSER40S	198	300	193	300	94	150	73	110
TSEW50S & TSER50S	225	350	220	350	111	175	81	125
TSEW60S & TSER60S	271	400	266	400	137	225	99	150
TSEW80S & TSER80S	N/A	N/A	N/A	N/A	184	300	136	200
TSEW20D & TSER20D	106	125	104	125	53	70	41	50
TSEW30D & TSER30D	165	200	162	200	84	100	87	110
TSEW40D & TSER40D	227	300	224	300	108	150	87	110
TSEW50D & TSER50D	251	300	248	300	126	175	105	150
TSEW60D & TSER60D	273	350	269	350	139	175	122	150
TSEW80D & TSER80D	377	500	372	450	180	225	141	175
TSEW100D & TSER100D	434	600	429	600	217	300	156	200
TSEW120D & TSER120D	545	700	538	700	278	350	199	250
TSEW160D & TSER160D	N/A	N/A	N/A	N/A	372	450	273	350

Model	Chiller with High Flow Pumps							
	Rated Voltage <sup>1</sup> FLA @ 208		Rated Voltage <sup>1</sup> FLA @ 230		Rated Voltage <sup>1</sup> FLA @ 460		Rated Voltage <sup>1</sup> FLA @ 575	
	MCA <sup>2</sup>	MOP <sup>3</sup>	MCA <sup>2</sup>	MOP <sup>3</sup>	MCA <sup>2</sup>	MOP <sup>3</sup>	MCA <sup>2</sup>	MOP <sup>3</sup>
TSEW10S & TSER10S	68	90	66	90	33	45	26	35
TSEW15S & TSER15S	102	150	99	150	51	70	42	60
TSEW20S & TSER20S	138	200	135	200	65	90	53	70
TSEW25S & TSER25S	149	200	146	200	74	100	62	90
TSEW30S & TSER30S	161	225	158	225	81	110	71	100
TSEW40S & TSER40S	224	300	219	300	106	150	84	125
TSEW50S & TSER50S	254	350	249	350	126	175	92	125
TSEW60S & TSER60S	319	450	313	450	161	225	117	175
TSEW80S & TSER80S	N/A	N/A	N/A	N/A	211	300	156	225

Model	Chiller with High Flow Pumps (continued)							
	Rated Voltage <sup>1</sup> FLA @ 208		Rated Voltage <sup>1</sup> FLA @ 230		Rated Voltage <sup>1</sup> FLA @ 460		Rated Voltage <sup>1</sup> FLA @ 575	
	MCA <sup>2</sup>	MOP <sup>3</sup>	MCA <sup>2</sup>	MOP <sup>3</sup>	MCA <sup>2</sup>	MOP <sup>3</sup>	MCA <sup>2</sup>	MOP <sup>3</sup>
TSEW20D & TSER20D	123	175	119	150	61	80	47	60
TSEW30D & TSER30D	172	225	168	200	87	110	70	90
TSEW40D & TSER40D	243	300	238	300	115	150	93	110
TSEW50D & TSER50D	267	350	262	350	133	175	111	150
TSEW60D & TSER60D	303	400	295	350	152	200	133	175
TSEW80D & TSER80D	406	500	398	500	193	250	151	200
TSEW100D & TSER100D	476	600	467	600	236	300	171	225
TSEW120D & TSER120D	601	800	588	700	303	400	219	300
TSEW160D & TSER160D	N/A	N/A	N/A	N/A	390	500	287	350

Model & Circuit Type	Remote Condensers							
	Rated Voltage <sup>1</sup> FLA @ 208		Rated Voltage <sup>1</sup> FLA @ 230		Rated Voltage <sup>1</sup> FLA @ 460		Rated Voltage <sup>1</sup> FLA @ 575	
	MCA <sup>2</sup>	MOP <sup>3</sup>	MCA <sup>2</sup>	MOP <sup>3</sup>	MCA <sup>2</sup>	MOP <sup>3</sup>	MCA <sup>2</sup>	MOP <sup>3</sup>
KCM014 Single Circuit	5.2	15	5.2	15	3	15	2	15
KCL023 Single Circuit	16	20	16	20	7	15	5.6	15
KCL030 Single Circuit	16	20	16	20	7	15	5.6	15
KCL037 Single Circuit	16	20	16	20	7	15	5.6	15
KCL045 Single Circuit	22	25	22	25	10	15	8	15
KCL056 Single Circuit	22	25	22	25	10	15	8	15
KCL068 Single Circuit	31	35	31	35	16	20	11	15
KCL095 Single Circuit	41	45	41	45	16	20	16	20
KCL110 Single Circuit	46	50	46	50	21	25	16	20

Model & Circuit Type	Remote Condensers (continued)							
	Rated Voltage <sup>1</sup> FLA @ 208		Rated Voltage <sup>1</sup> FLA @ 230		Rated Voltage <sup>1</sup> FLA @ 460		Rated Voltage <sup>1</sup> FLA @ 575	
	MCA <sup>2</sup>	MOP <sup>3</sup>	MCA <sup>2</sup>	MOP <sup>3</sup>	MCA <sup>2</sup>	MOP <sup>3</sup>	MCA <sup>2</sup>	MOP <sup>3</sup>
KCM034 Dual Circuit	10	15	10	15	5	15	4	15
KCM047 Dual Circuit	31	35	31	35	16	20	11	15
KCM060 Dual Circuit	31	35	31	35	16	20	11	15
KCL074 Dual Circuit	31	35	31	35	16	20	11	15
KCL090 Dual Circuit	46	50	46	50	21	25	16	20
KCL112 Dual Circuit	46	50	46	50	21	25	16	20
KCL137 Dual Circuit	61	70	61	70	31	35	21	25
KCL190 Dual Circuit	81	90	81	90	36	40	31	35
KCL224 Dual Circuit	91	100	91	100	46	50	36	40

<sup>1</sup>Allowable voltage is ± 10% from rated voltage.

<sup>2</sup>MCA is Minimum Circuit Amps, used for minimum wire size requirement.

<sup>3</sup>MOP is Maximum Overcurrent Protection, used for sizing main power protection device.

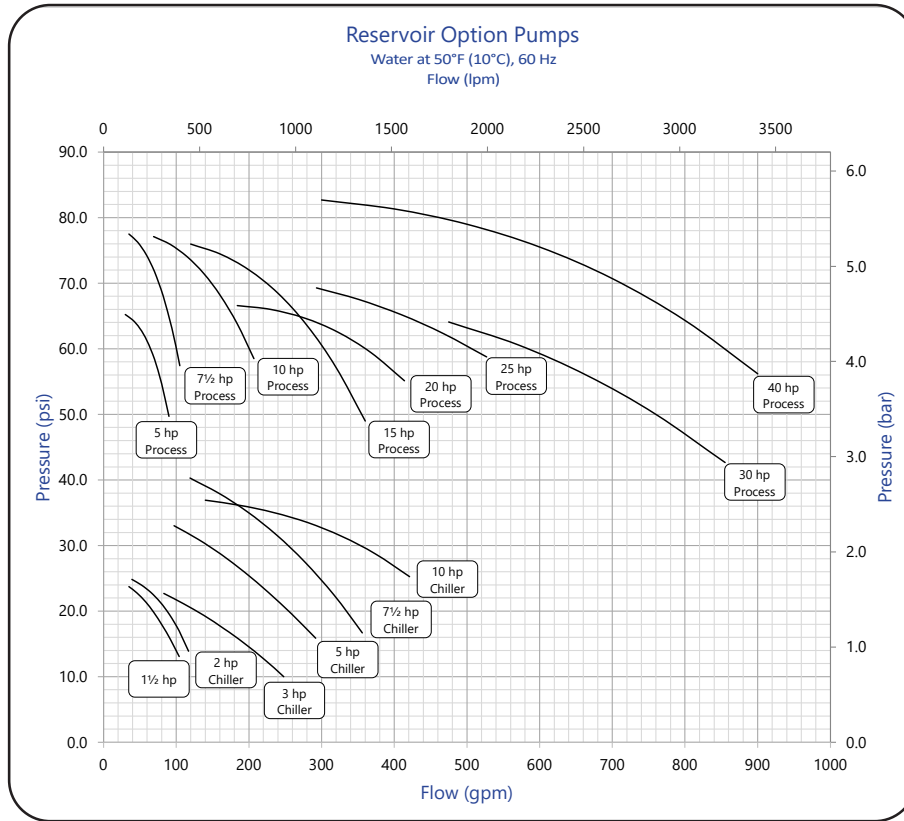

**Thermal Care is ISO 9001 Certified**  
Manufacturer reserves the right to change specification or design without notification or obligation.

